

DATA SHEET



PCF8813

**(67 + 1) × 102 pixels matrix LCD
driver**

Product specification
Supersedes data of 2002 Sep 24

2004 Mar 05

(67 + 1) × 102 pixels matrix LCD driver**PCF8813**

CONTENTS		
1	FEATURES	
2	APPLICATIONS	
3	GENERAL DESCRIPTION	
4	ORDERING INFORMATION	
5	BLOCK DIAGRAM	
6	PINNING	
7	FUNCTIONAL DESCRIPTION	
7.1	I/O buffer and interface	11.7
7.2	Oscillator	11.8
7.3	Address counter	11.9
7.4	Display data RAM	11.10
7.5	Timing generator	11.11
7.6	Display address counter	11.12
7.7	LCD row and column drivers	12
7.8	LCD waveforms and DDRAM to data mapping	13
7.9	DDRAM addressing	14
7.10	Data order	15
7.11	Mirror X	16
7.12	Mirror Y	17
7.13	Bottom row swap	17.1
7.14	Output row order	17.2
8	PARALLEL INTERFACES	17.3
8.1	6800-type parallel interface	17.4
8.2	8080-type parallel interface	17.4.1
9	SERIAL INTERFACES	17.4.2
9.1	Serial peripheral interface	17.5
9.1.1	Write mode	17.5.1
9.1.2	Read mode	17.5.2
9.2	Serial interface (3-line)	17.5.3
9.2.1	Write mode	17.6
9.2.2	Read mode	17.7
10	I ² C-BUS INTERFACE (Hs-MODE)	17.8
10.1	Characteristics of the I ² C-bus (Hs-mode)	17.9
10.1.1	System configuration	18
10.1.2	Bit transfer	18.1
10.1.3	Start and stop conditions	18.2
10.1.4	Acknowledge	18.3
10.2	I ² C-bus Hs-mode protocol	19
10.3	Command decoder	20
11	INSTRUCTIONS	21
11.1	Initialization	22
11.2	Reset function	23
11.3	Power-down mode	24
11.4	Display Control	25
11.5	Set Y address of RAM	
11.6	Set X address of RAM	
		Set maximum X address or Y address
		Set display start line, initial start row and row 0
		Set normal or partial display mode
		Free programmable multiplex rate
		Set HV generator stages
		Bias system
		TEMPERATURE COMPENSATION
		LIMITING VALUES
		HANDLING
		DC CHARACTERISTICS
		AC CHARACTERISTICS
		MODULE MAKER PROGRAMMING
		LCD voltage calibration
		Manufacturer identity
		Seal bit
		One time programming
		Architecture
		Operations
		Interface commands
		Disable OTP command
		Module maker calibration
		Refresh
		Filling the shift register
		Programming flow
		Programming specification
		Programming examples
		APPLICATION INFORMATION
		Protection from light
		Application examples
		Chip-on-glass applications
		DEVICE PROTECTION DIAGRAM
		BONDING PAD INFORMATION
		TRAY INFORMATION
		DATA SHEET STATUS
		DEFINITIONS
		DISCLAIMERS
		PURCHASE OF PHILIPS I ² C COMPONENTS

(67 + 1) × 102 pixels matrix LCD driver**PCF8813****1 FEATURES**

- Single-chip LCD controller or driver
- 67 row + 1 icon row, 102 column outputs (the icon row is available twice to allow icons to be displayed at the top or at the bottom of the display)
- Very low power consumption, optimized for battery operated systems
- On-chip:
 - Display data RAM 68 × 102 bits
 - Configurable voltage multiplier (× 5, × 4, × 3 and × 2) generating highly accurate V_{LCD} and includes booster capacitors (external V_{LCD} is also possible)
 - Temperature compensation of V_{LCD} with four selectable temperature coefficients
 - Generation of intermediate LCD bias voltages
 - Highly-accurate built-in oscillator requiring no external components (an external clock is also possible)
- High integration level resulting in minimum number of external capacitors and resistors
- Selectable 8-bit parallel interface, 3-line or 4-line Serial Peripheral Interface (SPI), 3-line serial interface and high-speed I²C-bus interface
- External reset input
- CMOS compatible inputs
- Mux rates: 1 : 9 to 1 : 65 in steps of 8 and 1 : 68
- Logic supply voltage range 1.7 to 3.3 V
- High voltage generator supply voltage range 2.4 to 4.5 V
- Display supply voltage range 3.0 to 9.0 V
- One Time Programmable (OTP) V_{LCD} trimming
- Horizontal and vertical mirroring
- Status read which allows chip recognition and content checking of some registers



- Start address line which allows, for instance, scrolling of the displayed image
- Programmable display RAM pointers for various display sizes
- Slim chip layout optimized for chip-on-glass applications
- Operating temperature range –40 to +85 °C
- Very close tolerance on V_{LCD} and frame frequency for excellent optical performance
- Support for LCD cell tolerance compensation of V_{LCD} by OTP storage.

2 APPLICATIONS

- Telecom equipment
- Portable instruments
- Point of sale terminals.

3 GENERAL DESCRIPTION

The PCF8813 is a low power CMOS LCD controller driver designed to drive a graphic display of 67 rows and 102 columns plus an icon row of up to 102 symbols. All necessary functions for the display are provided in a single chip, including on-chip generation of the LCD supply and bias voltages, resulting in a minimum of external components and low power consumption. The PCF8813 can interface to microcontrollers via a parallel, serial or I²C-bus interface.

4 ORDERING INFORMATION

TYPE NUMBER	PACKAGE		
	NAME	DESCRIPTION	VERSION
PCF8813U/2DA/2	–	chip with bumps in tray for COG	–

(67 + 1) × 102 pixels matrix LCD driver

PCF8813

5 BLOCK DIAGRAM

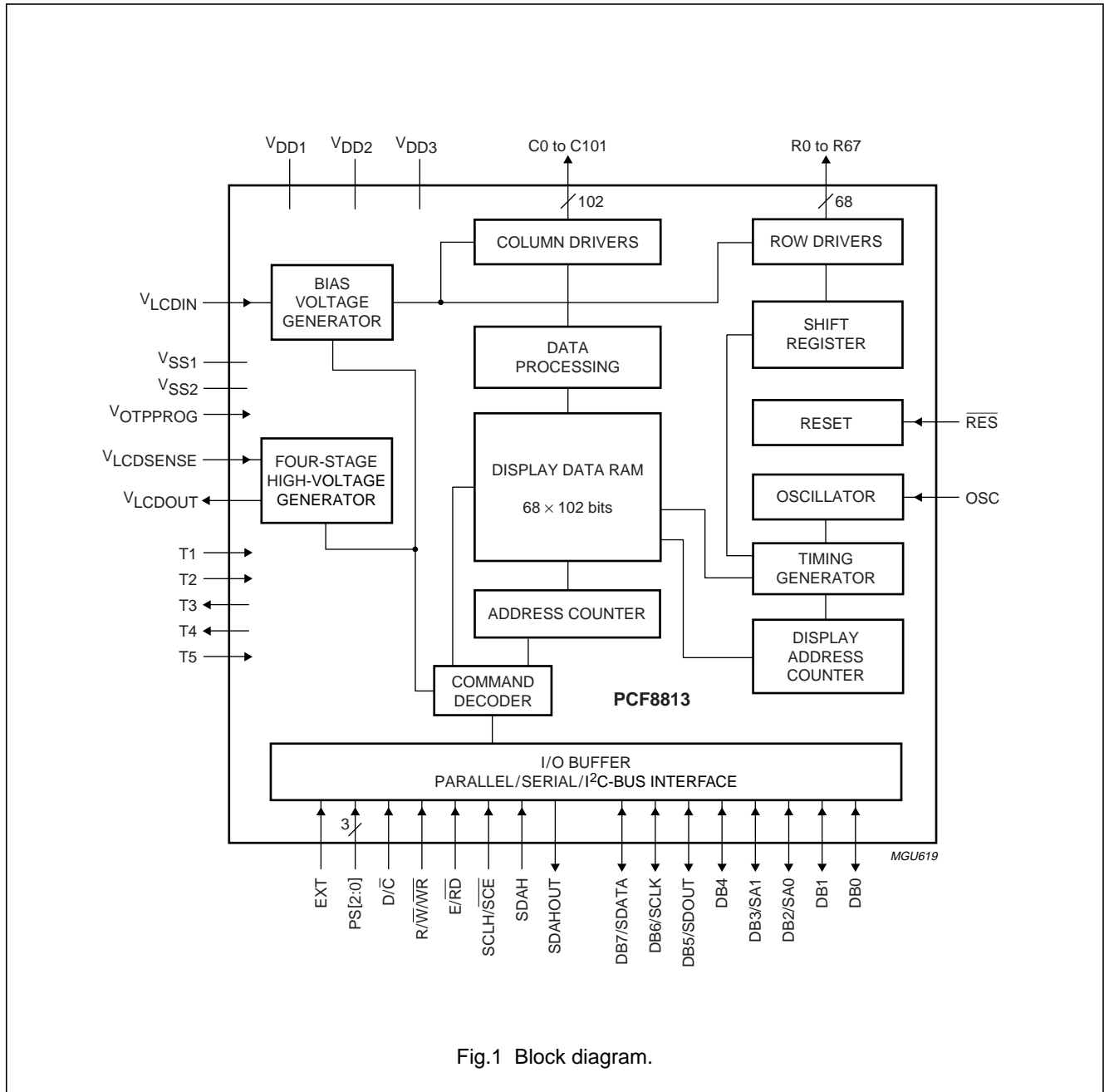

Fig.1 Block diagram.

$(67 + 1) \times 102$ pixels matrix LCD driver

PCF8813

6 PINNING

SYMBOL	PAD ⁽¹⁾	DESCRIPTION
R15 to R0	7 to 22	LCD row driver outputs
R16 to R31	23 to 38	
C0 to C101	39 to 140	LCD column driver outputs
R67	141	LCD row driver output for row 67 (used only for icons)
R66 to R48	142 to 160	LCD row driver outputs
R32 to R47	161 to 176	
R67	177	duplicated LCD row driver output for row 67 (used only for icons)
SDAHOUT	183	data output for I ² C-bus interface; notes 2 and 3
SDAH	184 to 185	data output for I ² C-bus interface; note 2
V _{DD1}	186 to 191	supply voltage 1; note 4
V _{DD3}	192 to 196	supply voltage 3; note 4
V _{DD2}	197 to 206	supply voltage 2; note 4
V _{DD1}	207	supply voltage 1; notes 4 and 5
R/W/WR	208	READ/WRITE (6800) or WRITE (8080 interface) input; note 6
E/RD	209	clock enable (6800 interface) or READ (8080 interface) input; note 7
DB0	210	parallel data input/output; note 8
DB1	211	parallel data input/output; note 8
DB2/SA0	212	parallel data input/output or I ² C-bus slave address input (bit 0)
DB3/SA1	213	parallel data input/output or I ² C-bus slave address input (bit 1)
DB4	214	parallel data input/output; note 8
DB5/SDOUT	215	parallel data input/output or serial output (SDOUT)
DB6/SCLK	216	parallel data input/output or output or serial clock input (SCLK)
DB7/SDATA	217	parallel data input/output or serial data input (SDATA)
V _{SS1}	218	ground voltage 1; notes 5 and 9
D/C	219	data/command; note 10
SCE/SCLH	220 to 221	chip enable or clock input for I ² C-bus interface
V _{OTPPROG}	222 to 224	voltage inputs for OTP programming; see note 11
V _{DD1}	225	supply voltage 1; notes 4 and 5
OSC	226	oscillator input; note 12
V _{SS2}	227 to 236	ground voltage 2; note 9
V _{SS1}	237 to 246	ground voltage 1; note 9
T5	247	test input 5; note 13
T1	248	test input 1; note 13
T2	249	test input 2; note 13
PS0	250	parallel/serial/I ² C-bus data input selection pad 0
PS1	251	parallel/serial/I ² C-bus data input selection pad 1
PS2	252	parallel/serial/I ² C-bus data input selection pad 2
V _{DD1}	253	supply voltage 1; notes 4 and 5
T4	254	test output 4; note 13
T3	255	test output 3; note 13

$(67 + 1) \times 102$ pixels matrix LCD driver

PCF8813

SYMBOL	PAD ⁽¹⁾	DESCRIPTION
V _{LCDIN}	256 to 262	LCD supply voltage input; note 14
V _{LCDOUT}	263 to 271	generated LCD supply voltage; note 14
V _{LCDSENSE}	272	voltage multiplier (V _{LCD}) regulation input; note 14
RES	273	external reset input

Notes

- Dummy pads are located at positions 1, 2, 3, 5, 6, 179, 180, 181, 182 and 274; dummy and alignment pads are located at positions 4 and 178.
- When not in use, this pad must be connected to V_{DD1} or V_{SS1}.
- Output SDAHOUT is used as the data acknowledge output when the I²C-bus is selected. By connecting SDAHOUT to SDAH externally, the SDAH line becomes fully I²C-bus compatible. Having the acknowledge output separated from the serial data line is advantageous in COG applications because where the track resistance from the SDAHOUT pad to the SDAH line can be significant, a potential divider is generated by the bus pull-up resistor and the ITO track resistance. Therefore it is possible during the acknowledge cycle that the PCF8813 will not create a logic LOW level. By splitting the SDAH input from the SDAHOUT output, the device could be used in a mode that ignores the acknowledge bit. In COG applications where the acknowledge cycle is required, it is necessary to minimize the track resistance from the SDAHOUT pad to the system SDAH line to guarantee a valid LOW level.
- V_{DD2} and V_{DD3} supply the internal voltage generator, both have the same voltage and may be connected together outside of the chip; V_{DD1} supplies the remainder of the chip. V_{DD1}, V_{DD2} and V_{DD3} can be connected together but then care must be taken with respect to the supply voltage range. If the internal voltage generator is not used, pads V_{DD2} and V_{DD3} must be connected to pads V_{DD1}.
- This pad can be used to tie-off unused input pads to the power supply voltage or to ground.
- This input is not used in serial and I²C-bus mode and must therefore be connected to either V_{DD1} or V_{SS1}.
- This input is not used when the serial or I²C-bus interface is selected and must therefore be connected to V_{DD1} or V_{SS1}.
- When serial or I²C-bus mode is selected, the unused parallel pads must be connected to V_{DD1} or V_{SS1}.
- Supply rails V_{SS1} and V_{SS2} must be connected together.
- This input is not used with the 3-line serial interface and must therefore be connected to V_{DD1} or V_{SS1}.
- This pad can be connected externally to the $\overline{\text{SCE}}/\text{SCLH}$ pad to reduce the number of pads routed in COG applications. When not connected in this configuration, V_{OTPPROG} must be connected to either V_{DD1} or V_{SS1} after completion of OTP programming and after the seal bit has been set.
- When the on-chip oscillator is used, the OSC input must be connected to V_{DD1}. If an external clock signal is used, then this is connected to the OSC input. If both the oscillator and external clock are inhibited by connecting pad OSC to V_{SS1}, the display is not clocked and may be in a DC state. To avoid this, the chip should always be put into Power-down mode before stopping the clock.
- Test pads T1 to T5 are not accessible to users: T1, T2 and T5 must be connected to V_{SS}; T3 and T4 must be open-circuit.
- Positive power supply for the liquid crystal display (see also Figs 51, 52 and 53):
 - If the internal voltage generator is used, pads V_{LCDIN}, V_{LCDSENSE} and V_{LCDOUT} must be connected together.
 - An external LCD supply voltage can be supplied using the V_{LCDIN} pad, this requires that pad V_{LCDOUT} is open-circuit, pad V_{LCDSENSE} is connected to the V_{LCDIN} input, and the internal voltage generator is switched off. In Power-down mode, the external LCD supply voltage must be switched off.

(67 + 1) × 102 pixels matrix LCD driver**PCF8813****7 FUNCTIONAL DESCRIPTION****7.1 I/O buffer and interface**

One of five industrial standard interfaces can be selected using the interface configuration inputs PS2, PS1 and PS0.

Table 1 Parallel/serial/I²C-bus interface selection

PS2	PS1	PS0	INTERFACE
0	0	0	3-line SPI
0	0	1	4-line SPI
0	1	0	8080 parallel interface
0	1	1	6800 parallel interface
1	0	0	high-speed I ² C-bus interface
1	1	0	
1	0	1	3-line serial interface
1	1	1	

7.2 Oscillator

The on-chip oscillator provides the clock signal for the display system. No external components are required. An external clock signal, if used, is connected to this input.

7.3 Address counter

The Address Counter (AC) assigns addresses to the display data RAM for writing. The X address X[6:0] and the Y address Y[3:0] are set separately.

7.4 Display data RAM

The PCF8813 contains a 68 × 102 bit static RAM which stores the display data. The Display Data RAM (DDRAM) is divided into eight banks of 102 bytes (8 × 8 × 102 bits), one bank of 1 × 3 × 102 bits and a separate bank of 1 × 1 × 102 for icons. During RAM access, data is transferred to the RAM via any of the four interfaces. There is a direct correspondence between the X address and the column output number.

7.5 Timing generator

The timing generator produces the various signals required to drive the internal circuitry. Internal chip operation is not affected by operations on the data buses.

7.6 Display address counter

The display is generated by continuously shifting rows of RAM data to the dot matrix LCD via the column outputs. The display status (all dots on/off and normal/inverse video) is set by bits D and E in the display control command.

7.7 LCD row and column drivers

The PCF8813 contains 68 row and 102 column drivers, which connect the appropriate LCD bias voltages in a sequence to the display in accordance with the data that is to be displayed. Figure 2 shows typical waveforms. Unused outputs should be left unconnected.

$(67 + 1) \times 102$ pixels matrix LCD driver

PCF8813

7.8 LCD waveforms and DDRAM to data mapping

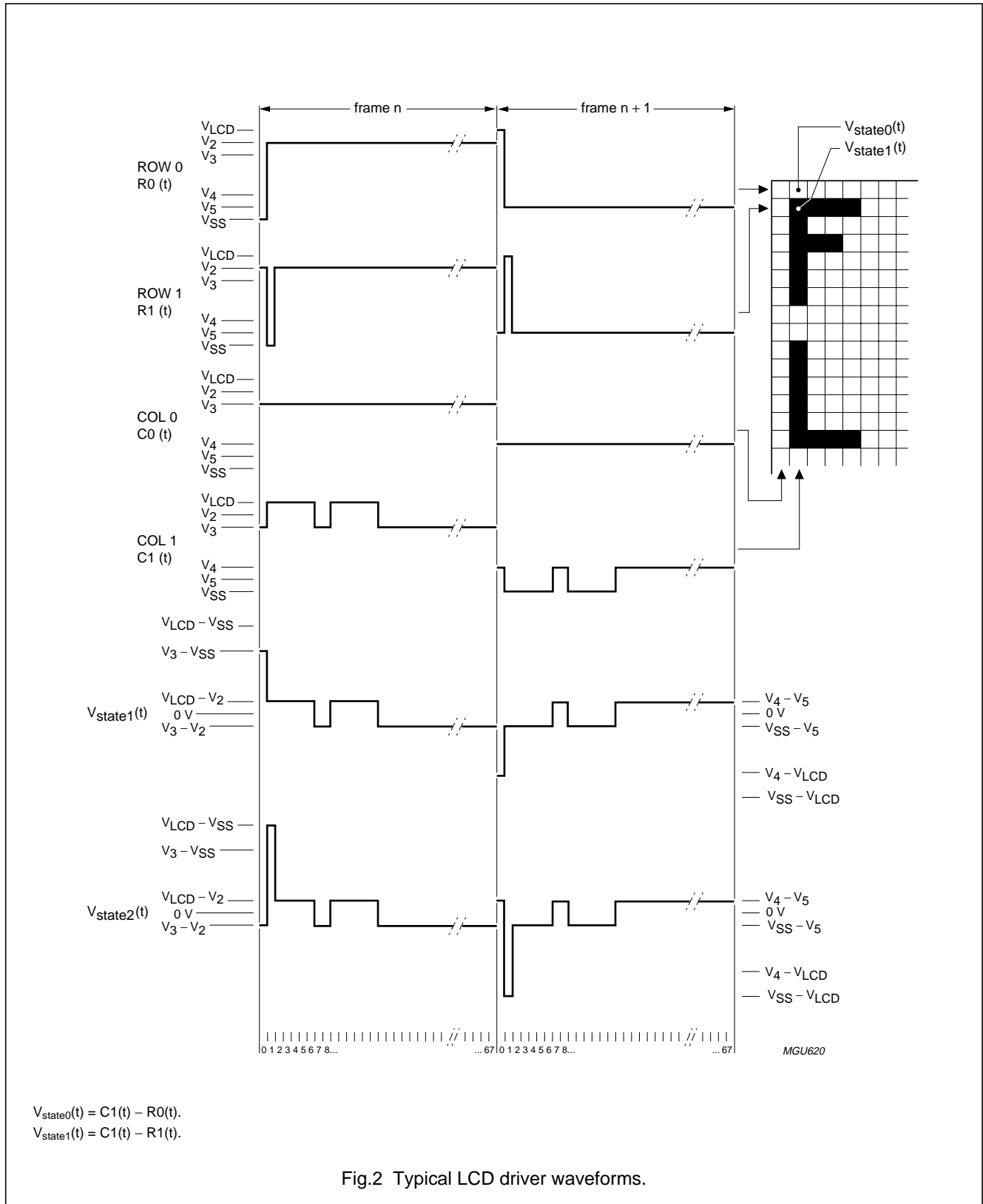

Fig.2 Typical LCD driver waveforms.

$(67 + 1) \times 102$ pixels matrix LCD driver

PCF8813

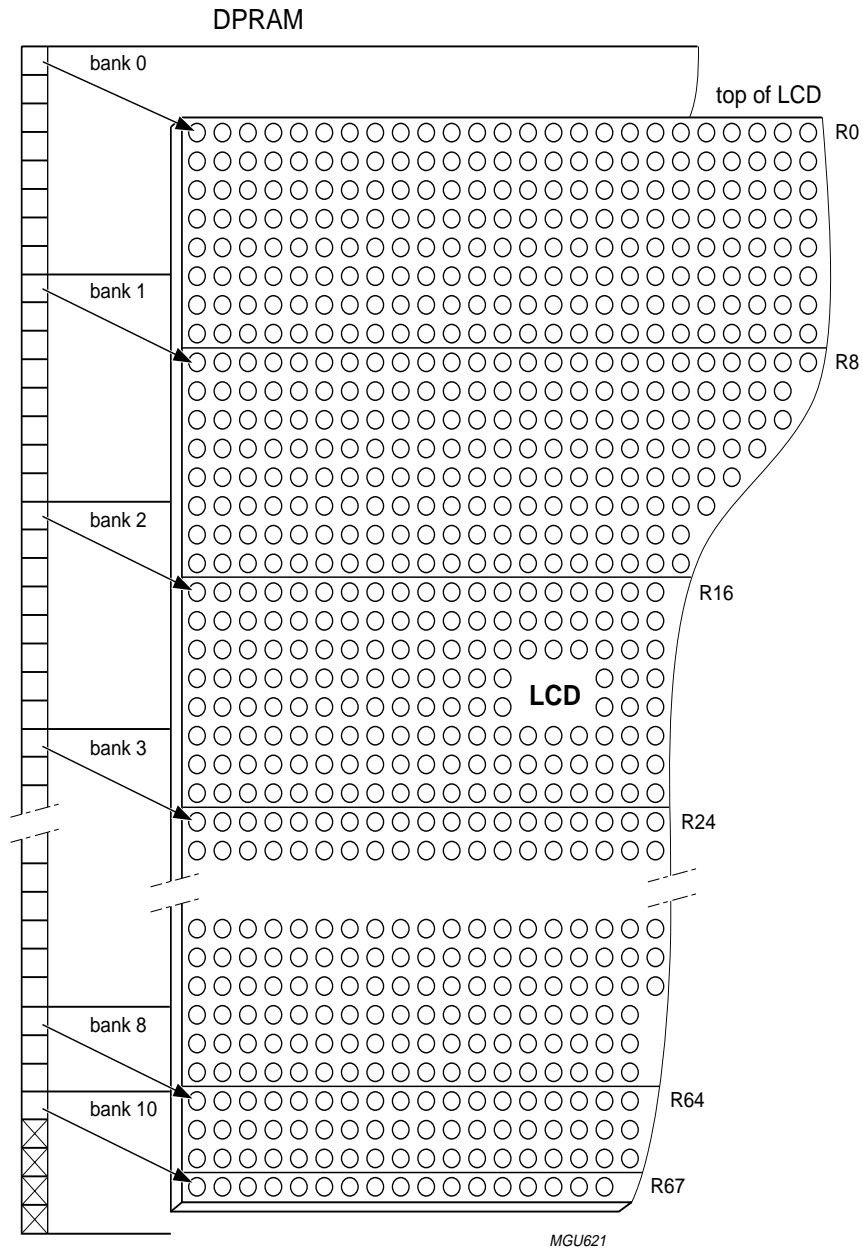

Fig.3 Display data RAM.

(67 + 1) × 102 pixels matrix LCD driver

PCF8813

7.9 DDRAM addressing

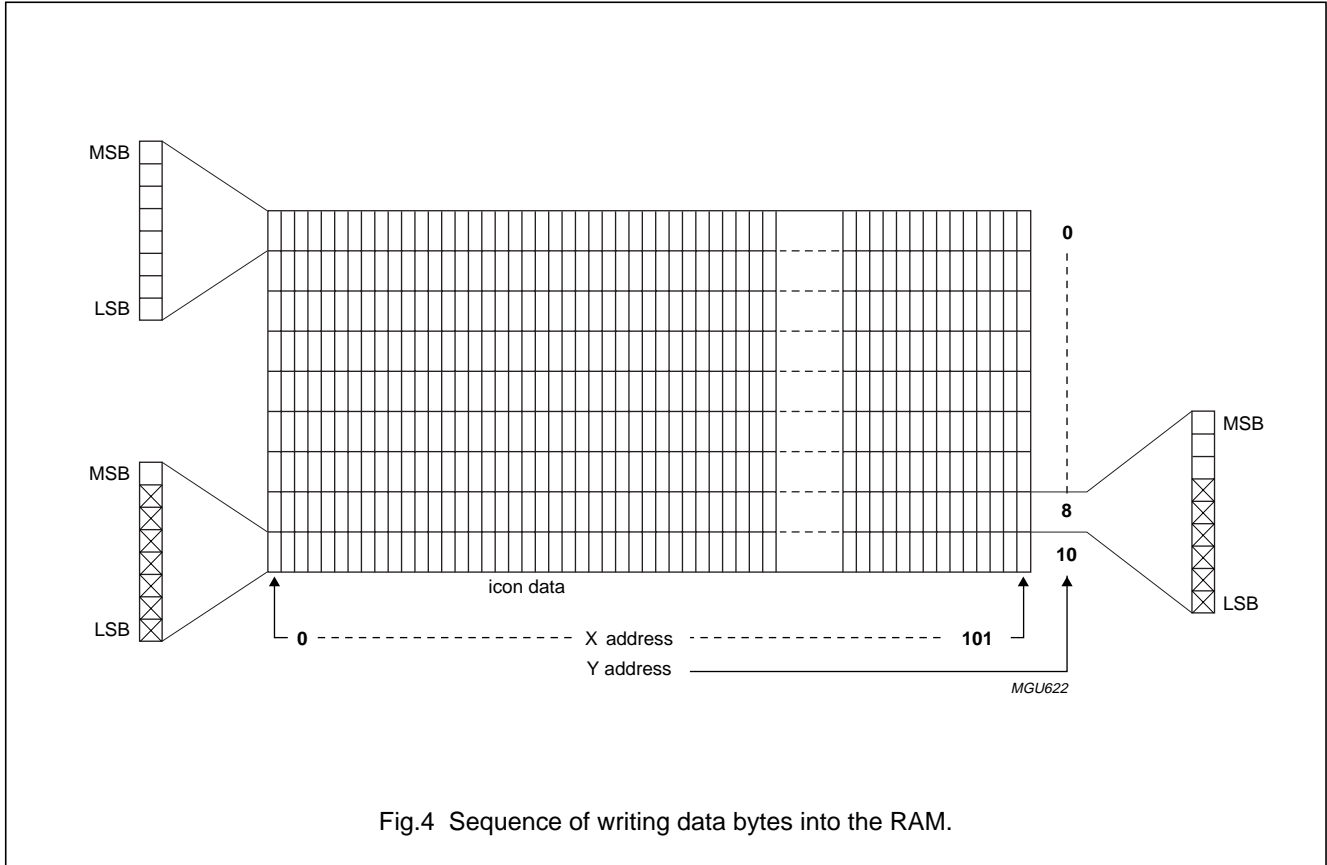

Fig.4 Sequence of writing data bytes into the RAM.

Data is downloaded in bytes into the RAM matrix of the PCF8813 as indicated in Fig.4. The display data RAM has a matrix of 68 by 102 bits. The columns are addressed by the X address pointer whilst the rows are addressed in groups of 8 by the Y address pointer. However, there are only three rows in bank 8 and one row in bank 10. There is no bank 9. Thus the address ranges are: X = 0 to 101 (1100101) and Y = 0 to 8 and then 10 (1010). The PCF8813 is limited to 102 columns by 68 rows, addressing the RAM outside this area is not allowed.

Two different addressing modes are possible; horizontal addressing and vertical addressing.

In the horizontal addressing mode (V = 0) the X address increments after each byte. After the last X address (X = 101), x wraps-around to 0 and Y increments to address the next row (see Fig.5) until bank 8 is filled. In the vertical addressing mode (V = 1) the Y address increments after each byte. After the Y address (Y = 8), there is Y wraparound to 0 and X increments to address the next column (see Fig.6). After the very last address (X = 101 and Y = 8) the address pointers wraparound to address X = 0 and Y = 0 in both addressing modes.

Addressing in bank 10 is a special case as these RAM locations are not automatically accessed. Bank 10 is reserved for icons. Icon locations must be addressed explicitly by setting the Y address pointer to 10. The Y address pointer does not auto-increment when the X address overflows or underflows (it stays in set to bank 9). Writing icon data is independent of the horizontal or vertical addressing (V-bit) but is affected by the Mirror X (MX) and Mirror Y (MY) bits. MX and MY are described in Sections 7.11 and 7.12.

$(67 + 1) \times 102$ pixels matrix LCD driver

PCF8813

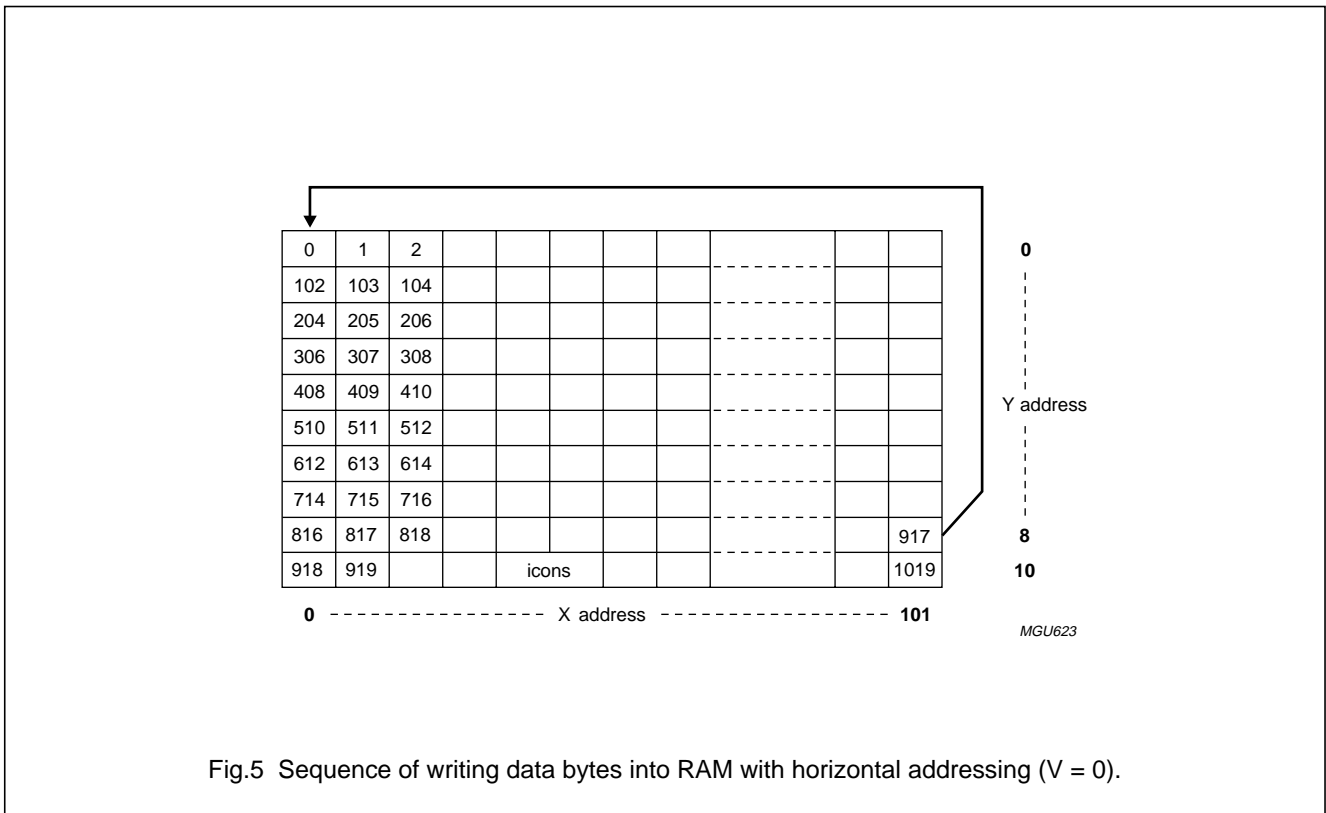

Fig.5 Sequence of writing data bytes into RAM with horizontal addressing (V = 0).

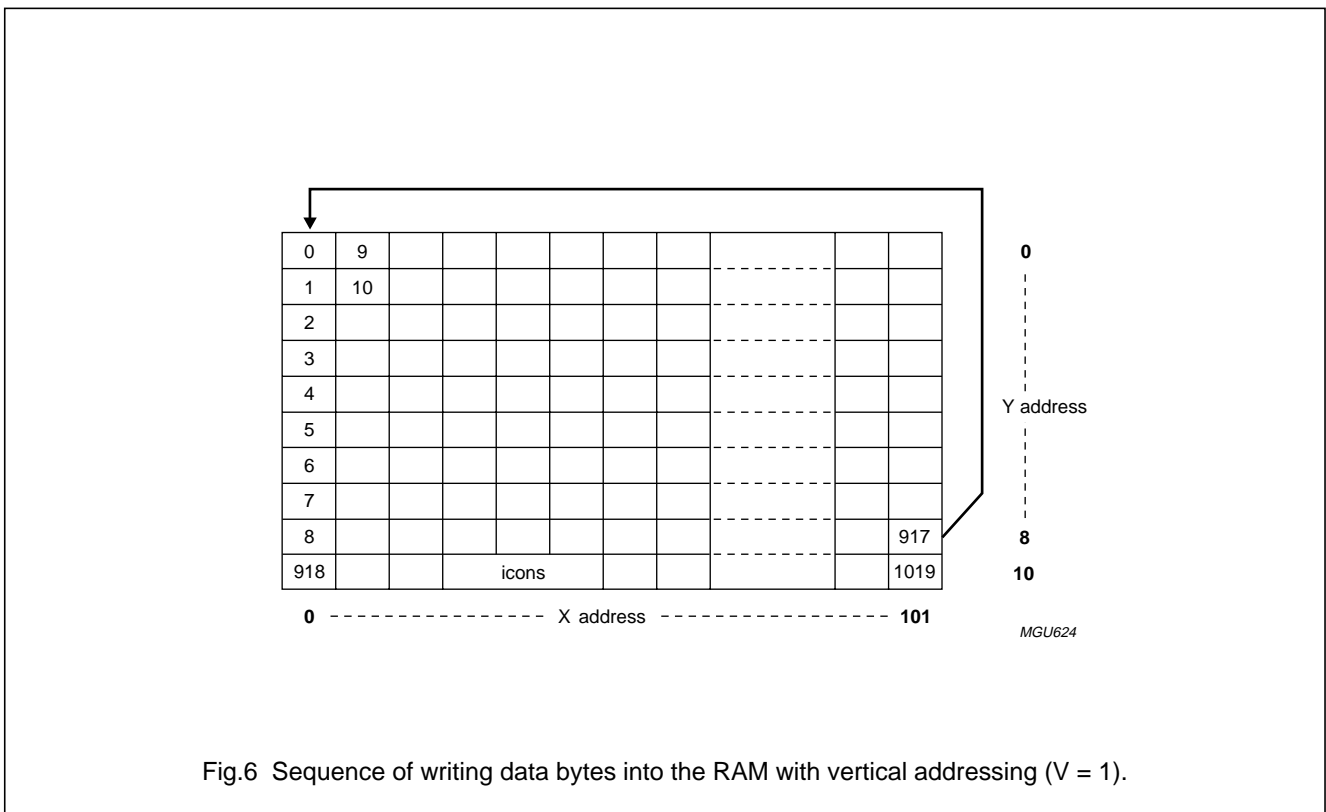

Fig.6 Sequence of writing data bytes into the RAM with vertical addressing (V = 1).

$(67 + 1) \times 102$ pixels matrix LCD driver

PCF8813

7.10 Data order

The Data Order bit (DO) defines the bit order (MSB on top or LSB on top) for writing in the RAM; see Figs 7 and 8.

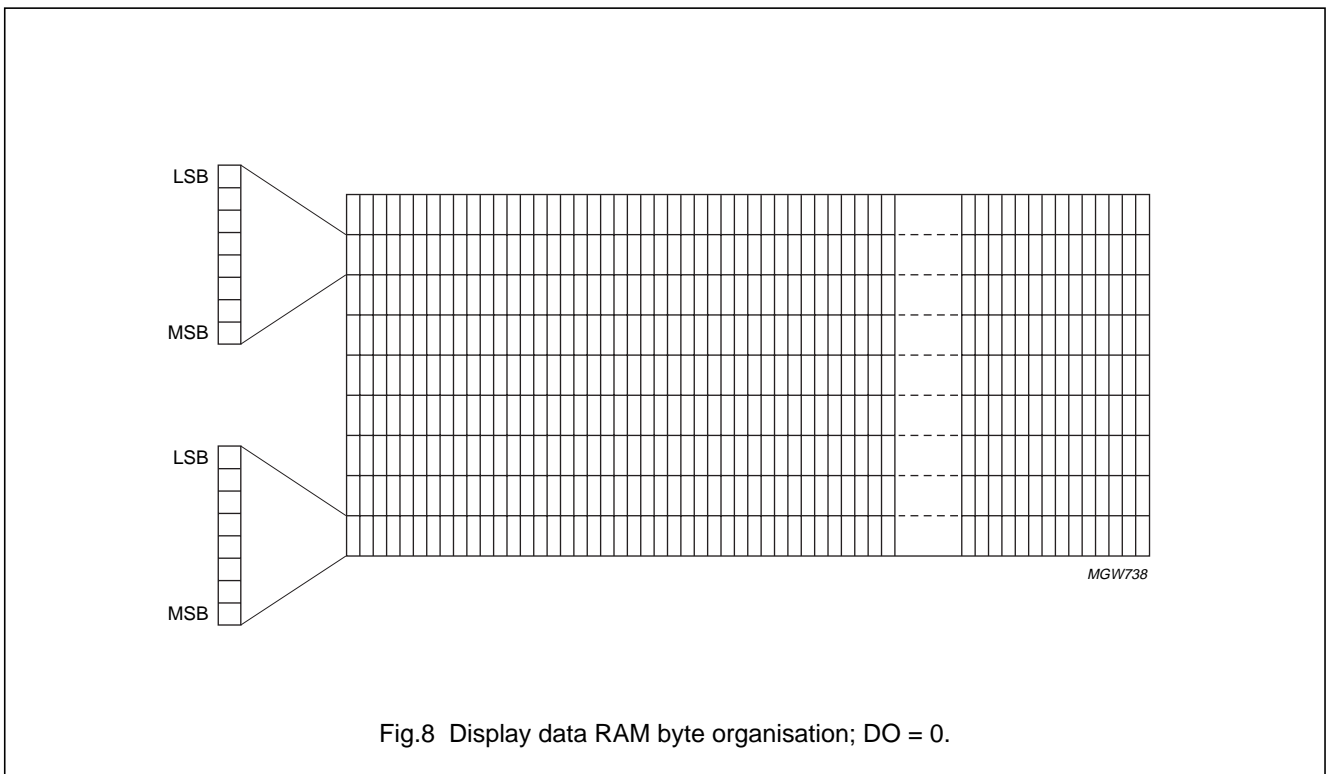
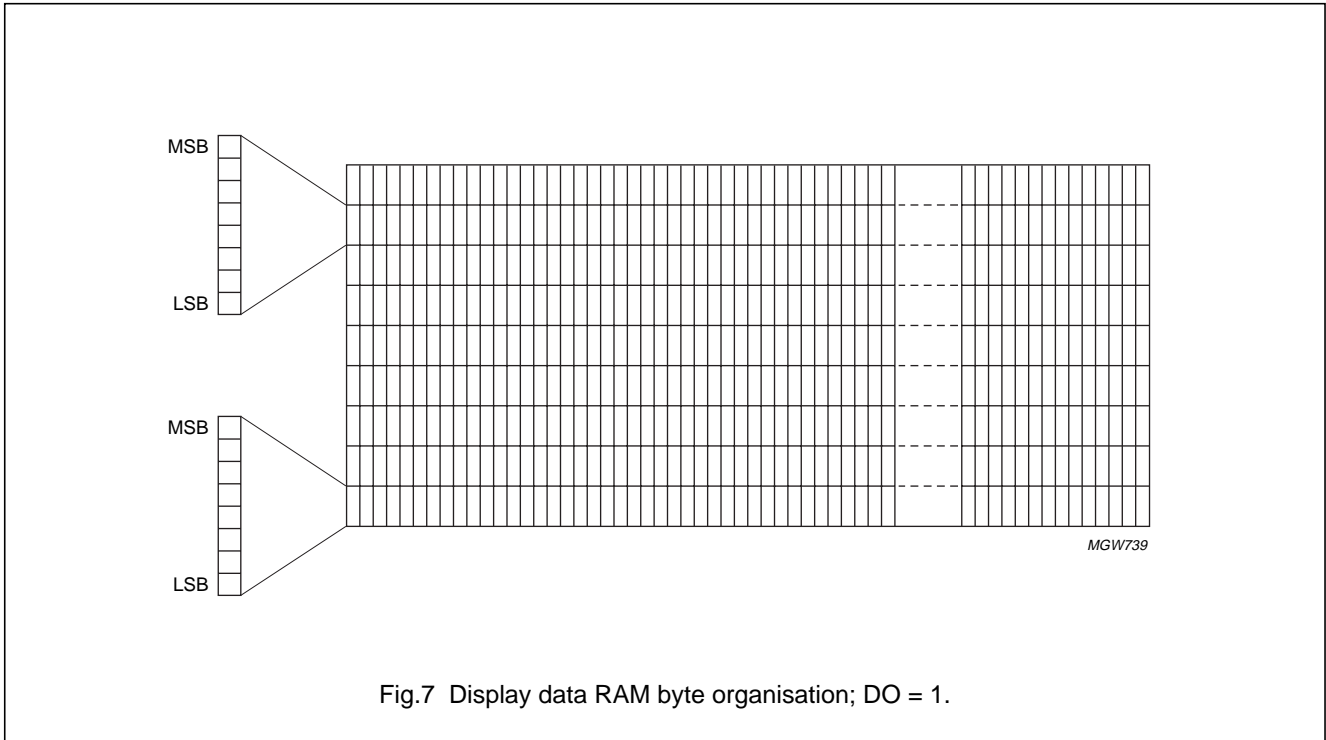

$(67 + 1) \times 102$ pixels matrix LCD driver

PCF8813

7.11 Mirror X

The MX bit allows horizontal mirroring. When $MX = 1$, the X address space is mirrored (see Fig.9). The address $X = 0$ is then located at the right side (column 101) of the display. When $MX = 0$, mirroring is disabled and the address $X = 0$ is located at the left side (column 0) of the display (see Fig.10).

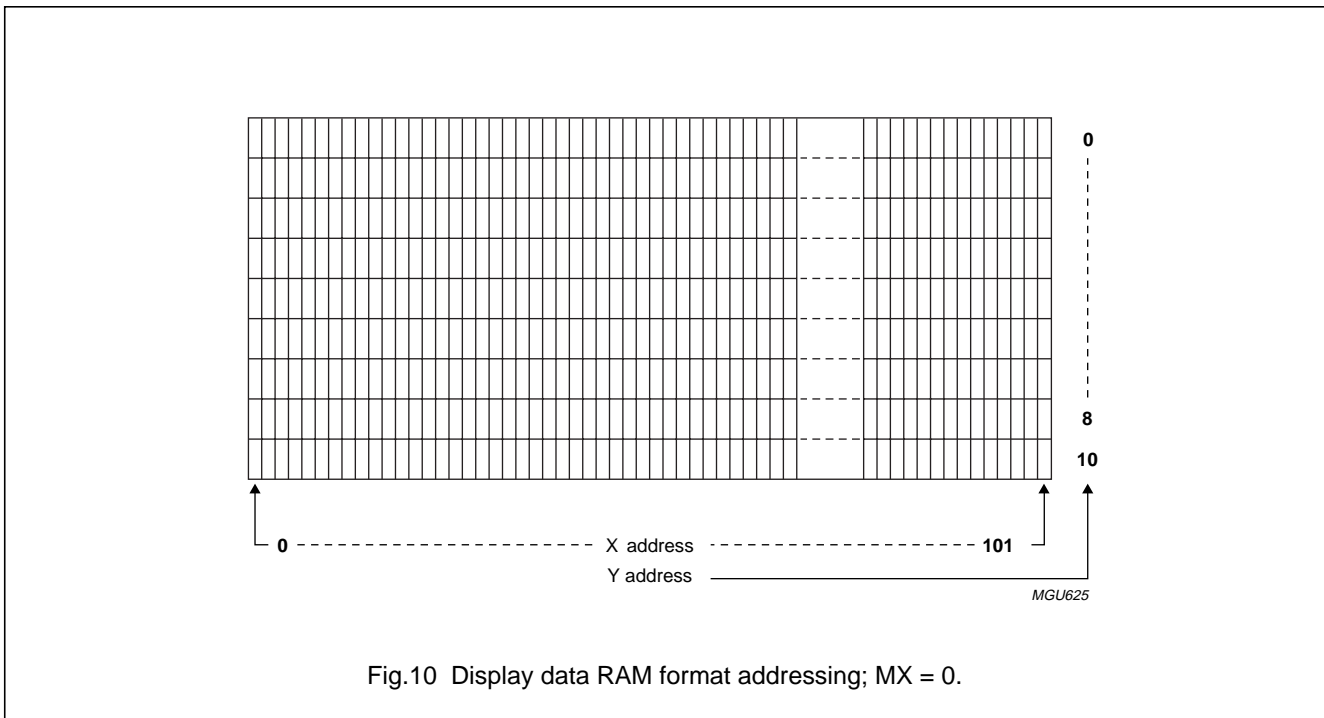
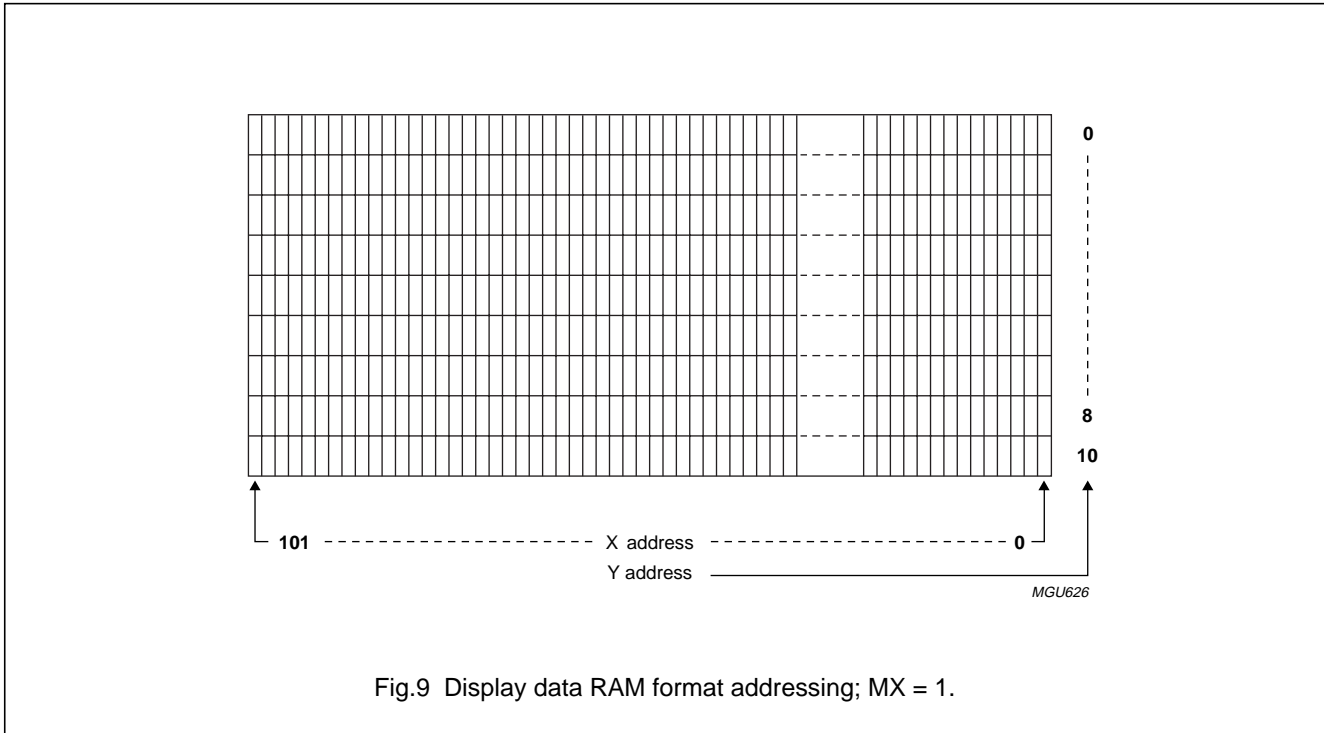

$(67 + 1) \times 102$ pixels matrix LCD driver

PCF8813

7.12 Mirror Y

The MY bit allows vertical mirroring. When MY = 1, the Y address space is mirrored resulting in an upside-down display. The address Y = 0 is then located at the bottom of the display (see Fig.11). When MY = 0, the mirroring is disabled and the address Y = 0 is located at top of the display (see Fig.12). A change in the state of MY has an immediate effect on the display and the effect of MY is visible immediately the bit is modified. This feature makes it possible to mount the device at the top or bottom of the display.

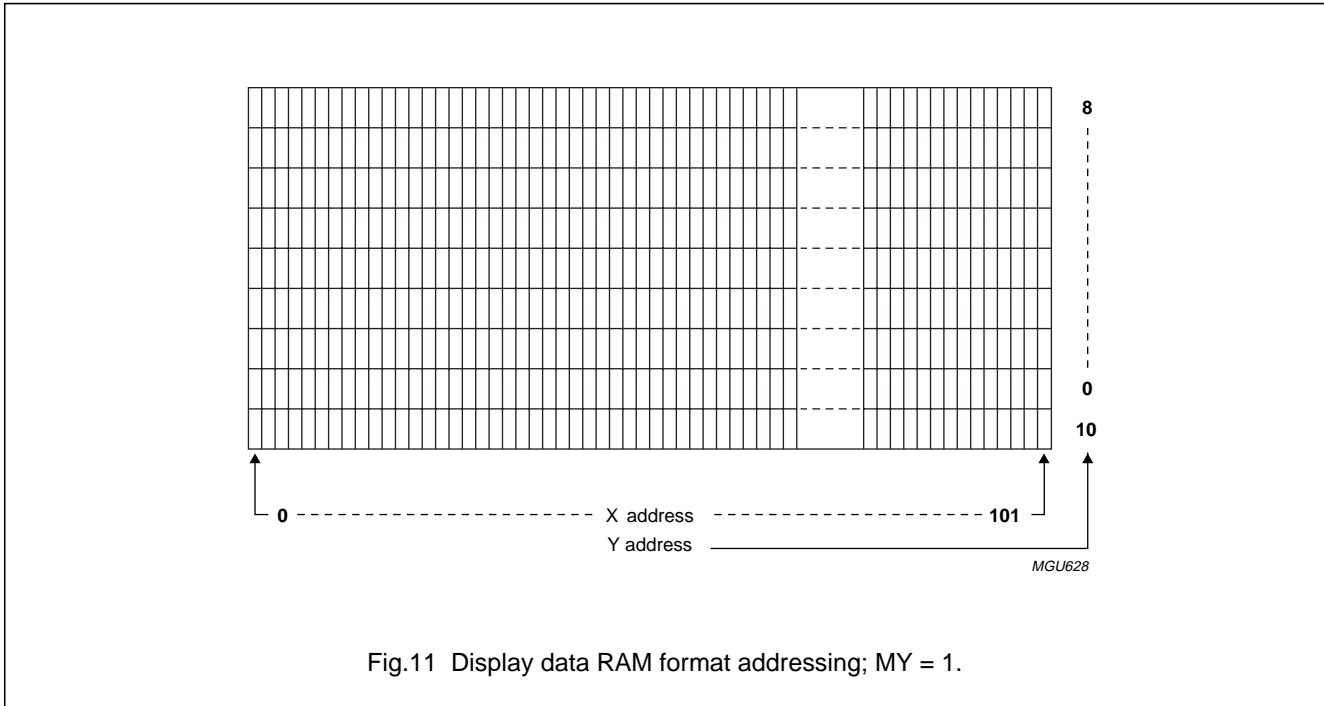

Fig.11 Display data RAM format addressing; MY = 1.

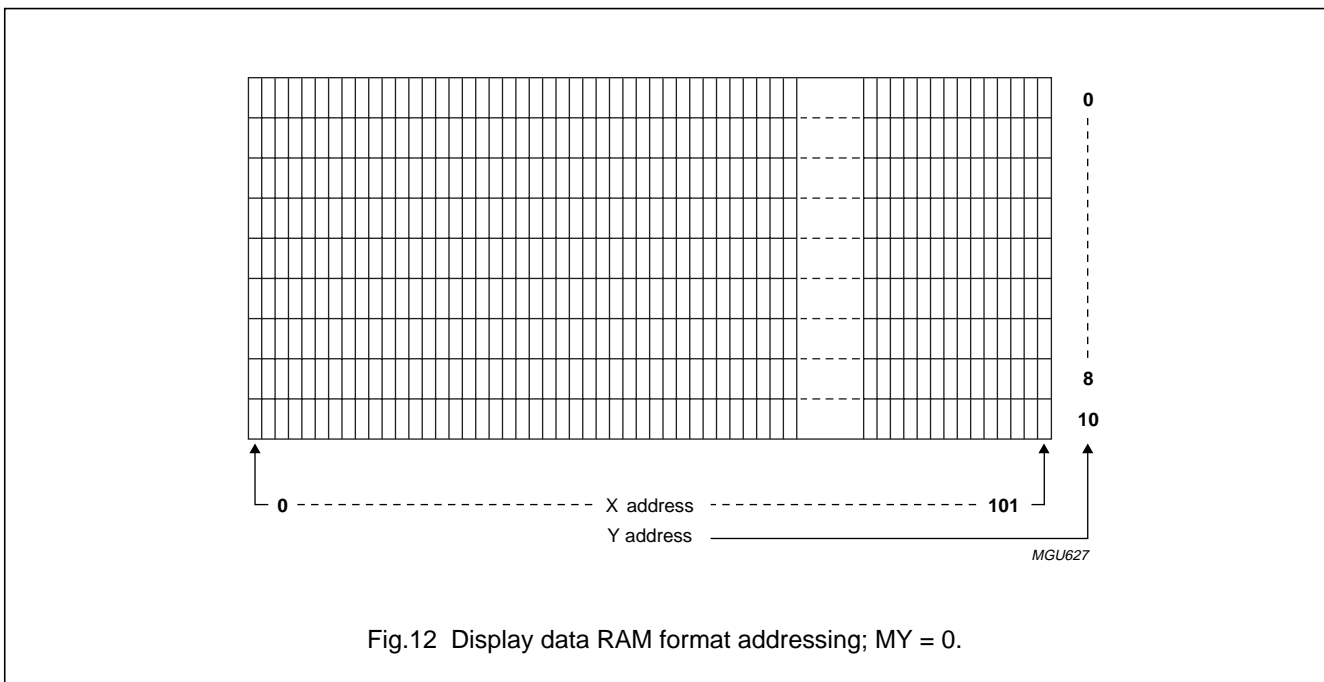

Fig.12 Display data RAM format addressing; MY = 0.

(67 + 1) × 102 pixels matrix LCD driver

PCF8813

7.13 Bottom row swap

This mode swaps the order of the order of the rows; see Figs 13 and 14. The mode is useful to aide routing to displays when it is not possible to pass tracks under the device, as in the case of Tape Carrier Packages (TCP).

7.14 Output row order

The order in which the rows are activated is a function of bits Bottom Row Swap (BRS), Mirror Y (MY) and Normal Partial mode (N/P). This has important implications when the device is used either in COG or TCP applications.

When MY is set to 0, the RAM is accessed in a linear manner, starting at R0, counting to R66, then jumping to

the end for the icon data. When MY is set to 1, the RAM is still accessed in a linear manner but starting from the last row, counting down to zero and then jumping to the icon data.

When N/P is set to 1, the Free Programmable Mux Rate (FPMR) mode is disabled and row addressing is in normal mode (see Section 11.9), therefore counting is the same as for MY = 0 and BRS = 0. When N/P is 0, FPMR mode is enabled. Only 65 rows are addressed/read in FPMR mode.

Figures 13 and 14 show the possibility of connecting the icon row (row R67) at the top or bottom of the display.

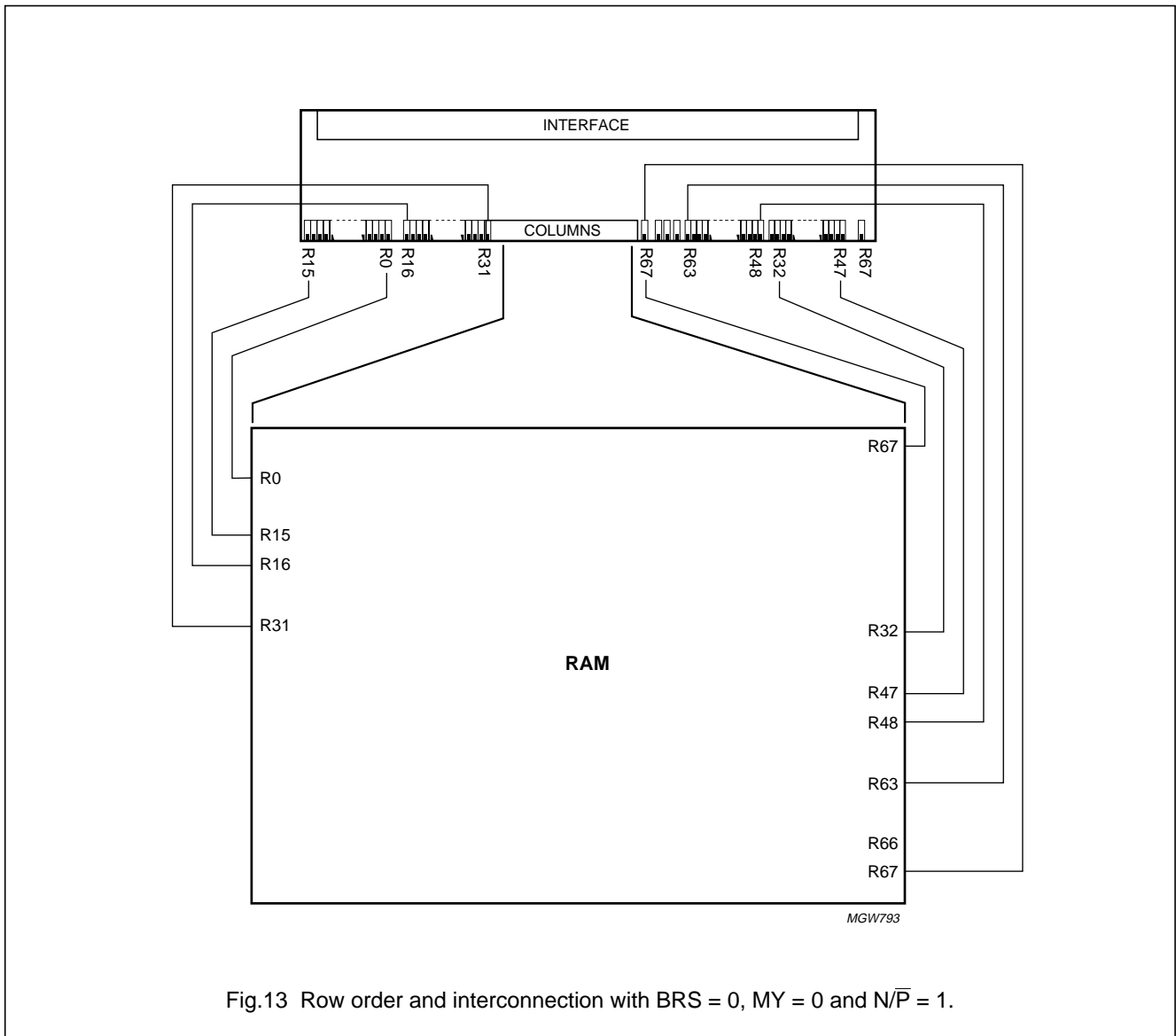

Fig.13 Row order and interconnection with BRS = 0, MY = 0 and N/P = 1.

$(67 + 1) \times 102$ pixels matrix LCD driver

PCF8813

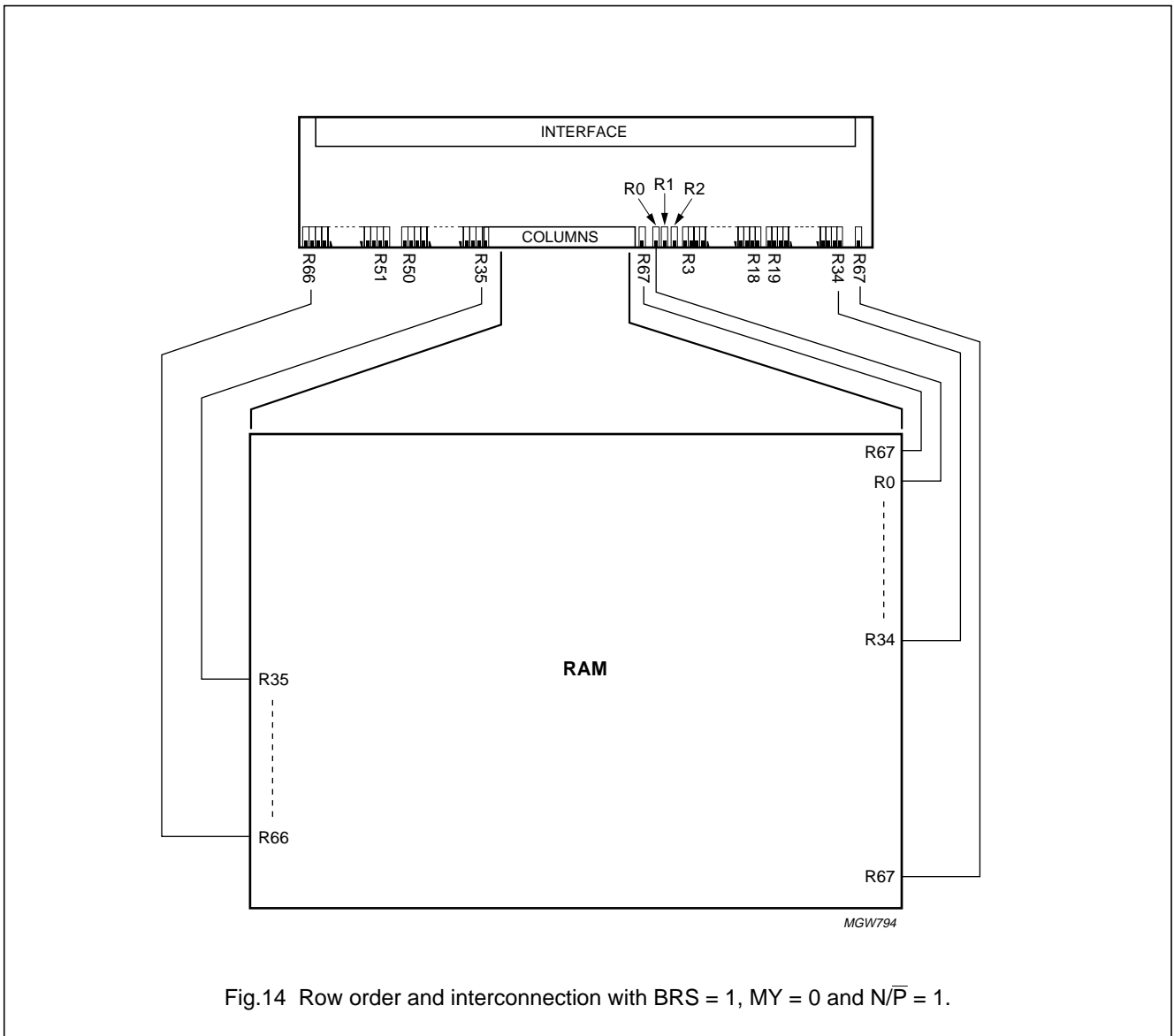

Fig.14 Row order and interconnection with BRS = 1, MY = 0 and $N/\bar{P} = 1$.

(67 + 1) × 102 pixels matrix LCD driver**PCF8813****8 PARALLEL INTERFACES**

The parallel interface is an 8-bit bidirectional interface for communication between the microcontroller and the LCD driver chip. Two different parallel interfaces can be selected by the inputs PS2, PS1 and PS0.

8.1 6800-type parallel interface

The interface functions of the 6800-type parallel interface are shown in Table 2.

Table 2 6800-type parallel interface function

D/C	R/WR	OPERATION
0	0	command data write
0	1	read status register
1	0	display data write
1	1	none

The 6800-type parallel interface can be configured to have the clock connected to the Enable input (E) with timing as shown in Fig.38, or with the clock connected to the chip select input (\overline{SCE}) and the Enable (E) is tied HIGH with timing as shown in Fig.39. The PCF8813 is capable of detecting these different modes automatically.

8.2 8080-type parallel interface

Table 3 shows the interface functions of the 8080-type parallel interface.

Table 3 6800-type parallel interface function

D/C	RD	WR	OPERATION
0	1	0	command data write
0	0	1	read status register
1	1	0	display data write
1	1	1	none

9 SERIAL INTERFACES

Communication with the microcontroller can also be via a clock-synchronized serial peripheral interface. It is possible to select two different 3-line interfaces (SPI and serial interface) or a 4-line serial interface (SPI). Selection of the interface is made with the inputs PS2, PS1 and PS0 (see Section 7.1).

9.1 Serial peripheral interface

The Serial Peripheral Interface (SPI) is a 3-line or 4-line interface for communication between the microcontroller and the LCD driver. The 3-line interface requires a chip enable input (\overline{SCE}), serial clock (SCLK) and serial data (SDATA). For the 4-line serial interface, a separate D/C line is added. The PCF8813 is connected to the serial data I/O (SDATA) of the microcontroller via the pads data input (SDATA) and data output (SDOUT) connected together.

9.1.1 WRITE MODE

The display data/command indication may be controlled via software or by the $\overline{D/C}$ select input. When the $\overline{D/C}$ input is used, display data is transmitted when $\overline{D/C}$ is HIGH, and command data is transmitted when $\overline{D/C}$ is LOW (see Figs 15 and 16). When $\overline{D/C}$ is not used, the display data length instruction is used to indicate that a specific number of display data bytes (1 to 256) are to be transmitted (see Fig.17). The byte that follows the display data string is handled as an instruction command.

If \overline{SCE} is pulled HIGH during a serial display data stream, the interrupted byte is invalid data but all previously transmitted data is valid. The next byte received will be handled as an instruction command (see Fig.18).

(67 + 1) × 102 pixels matrix LCD driver

PCF8813

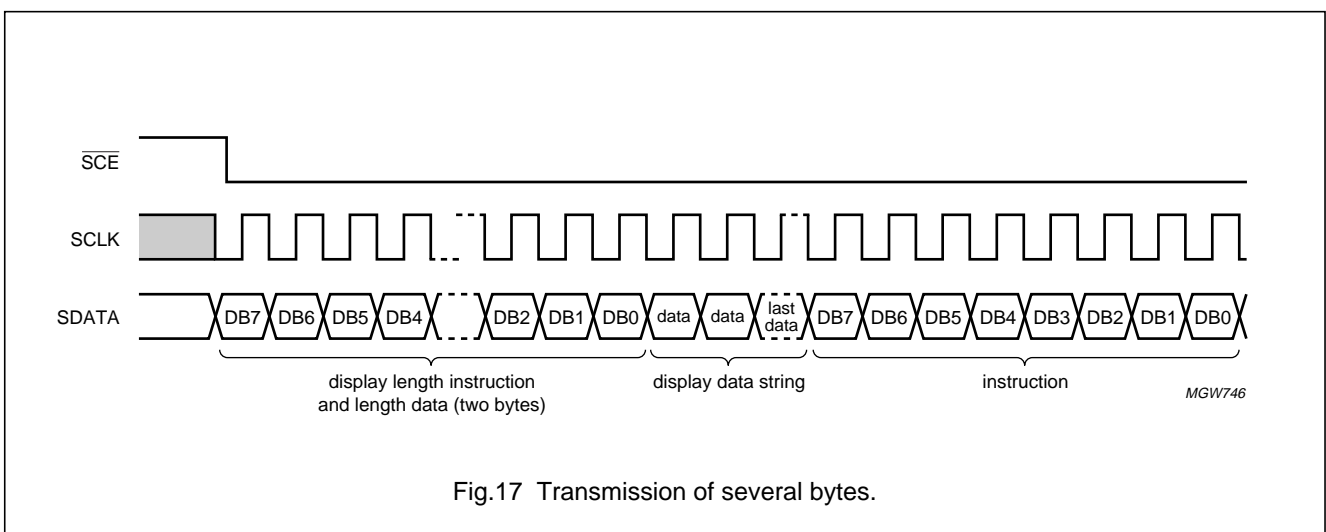
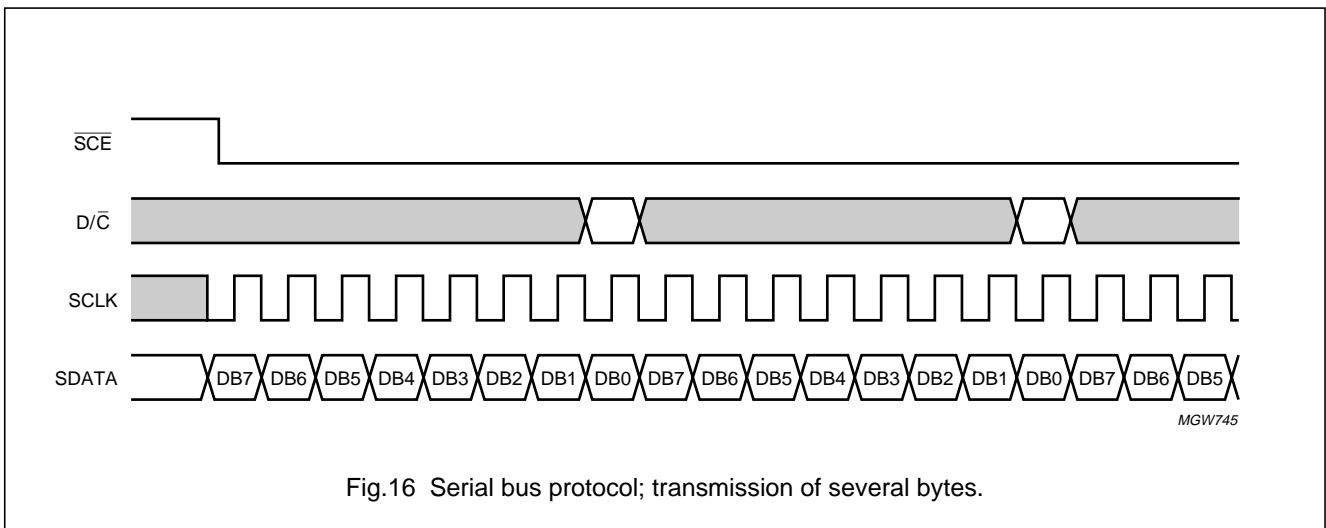
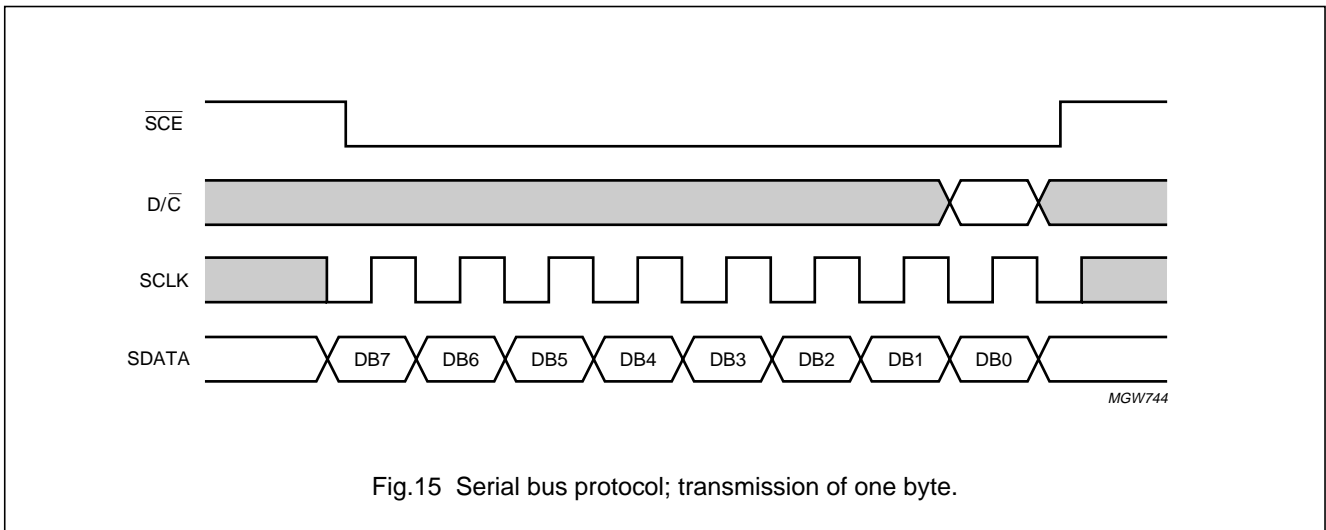

(67 + 1) × 102 pixels matrix LCD driver

PCF8813

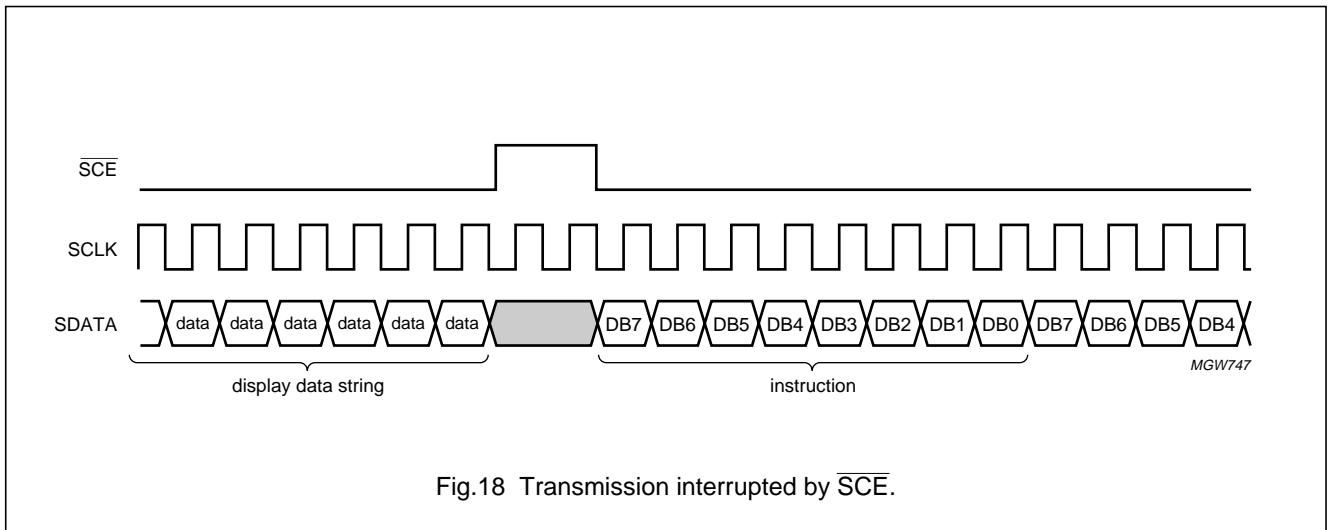

9.1.2 READ MODE

The interface read mode means that the microcontroller reads data from the PCF8813. To do so the microcontroller first has to send a command, the read status command, and then the PCF8813 will respond by transmitting data on the SDO line. After that SCE is required to go HIGH before a new command is sent (see Fig.17).

The PCF8813 samples SDATA at rising SCLK edges, but shifts SDO data at falling SCLK edges. Thus the microcontroller reads SDO data at rising SCLK edges.

After the read status command has been sent, the SDATA line must be set to 3-state not later than at the falling SCLK edge of the last bit (see Fig.19).

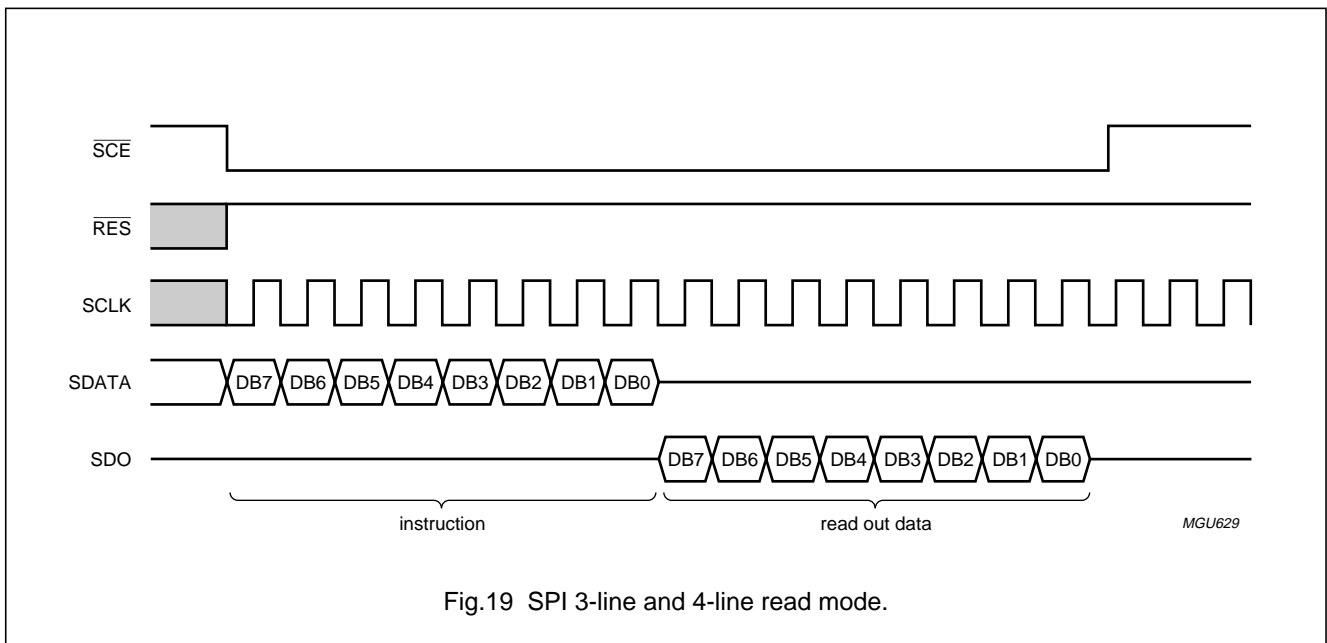

$(67 + 1) \times 102$ pixels matrix LCD driver

PCF8813

9.2 Serial interface (3-line)

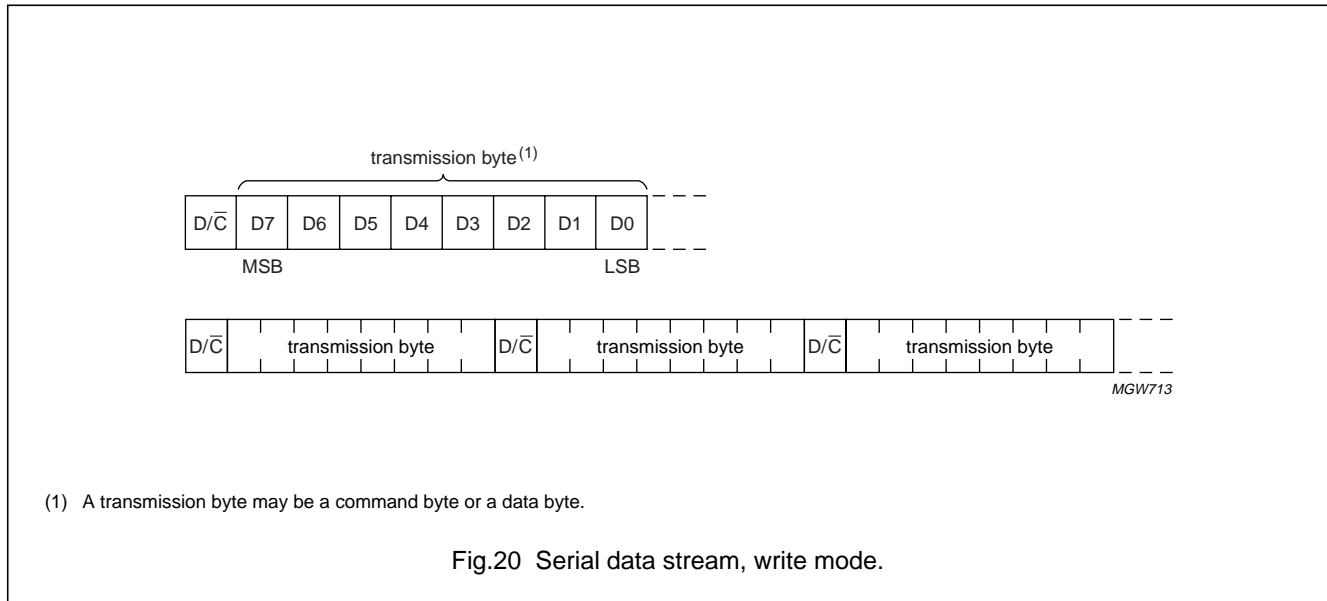

The serial interface is also a 3-line bidirectional interface for communication between the microcontroller and the LCD driver chip. The three lines are: \overline{SCE} (chip enable), SCLK (serial clock) and SDATA (serial data). The PCF8813 is connected to the SDA of the microcontroller by the SDATA (data input) and SDO (data output) pads which are connected together.

9.2.1 WRITE MODE

In the write mode of the interface, the microcontroller writes commands and data to the PCF8813. Each data packet contains a control bit D/\overline{C} and a transmission byte. If D/\overline{C} is LOW, the following byte is interpreted as a command byte. If D/\overline{C} is HIGH, the following byte is stored in the display data RAM. The address counter is incremented automatically after every data byte. Figure 20 shows the general format of the write mode and the definition of the transmission byte.

Any instruction can be sent in any order to the PCF8813. The MSB of a byte is transmitted first. The serial interface is initialized when \overline{SCE} is HIGH. In this state, SCLK clock pulses have no effect and no power is consumed by the serial interface. A falling edge on \overline{SCE} enables the serial interface and indicates the start of data transmission.

Figures 21, 22 and 23 show the protocol of the write mode:

- When \overline{SCE} is HIGH, SCLK clocks are ignored; the serial interface is initialized during the HIGH time of \overline{SCE} (see Fig.21)
- At the falling \overline{SCE} edge SCLK must be LOW (see Fig.41)
- SDATA is sampled at the rising edge of SCLK
- D/\overline{C} indicates whether the byte is a command ($D/\overline{C} = 0$) or RAM data ($D/\overline{C} = 1$); it is sampled with the first rising SCLK edge
- If \overline{SCE} stays LOW after the last bit of a command/data byte, the serial interface is ready for the D/\overline{C} -bit of the next byte at the next rising edge of SCLK (see Fig.22).
- A reset pulse with \overline{RES} interrupts the transmission and the data being written into the RAM may be corrupted. The registers are cleared. If \overline{SCE} is LOW after the rising edge of \overline{RES} , the serial interface is ready to receive the D/\overline{C} -bit of a command/data byte (see Fig.23).

(67 + 1) × 102 pixels matrix LCD driver

PCF8813

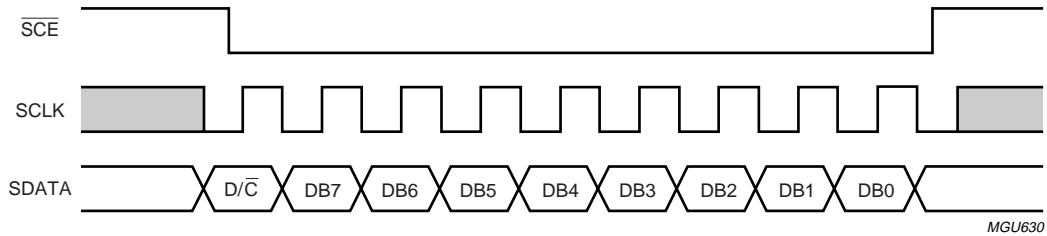

Fig.21 Serial interface (3-line), write mode - control bit followed by a transmission byte.

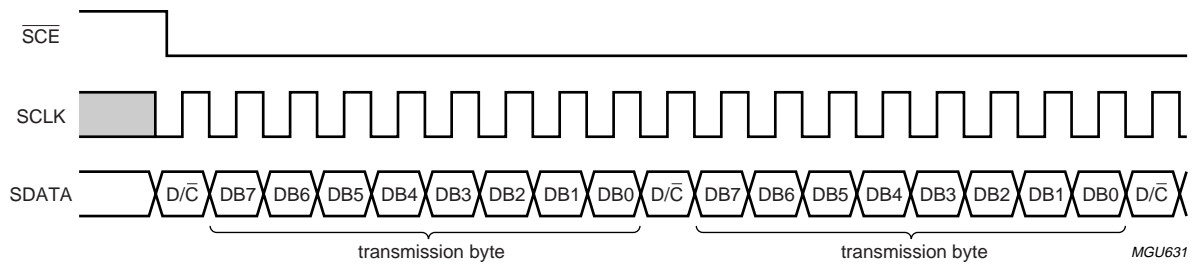

Fig.22 Serial interface (3-line), write mode - transmission of several bytes.

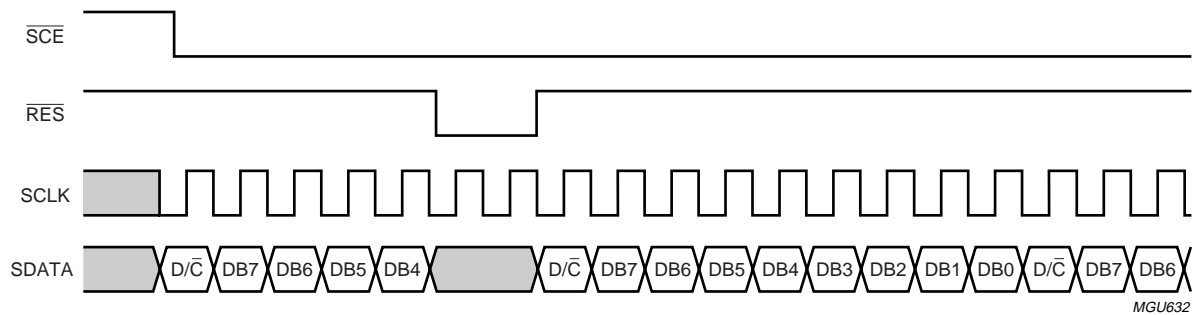

Fig.23 Serial interface (3-line), write mode - interrupted by reset (\overline{RES}).

(67 + 1) × 102 pixels matrix LCD driver

PCF8813

9.2.2 READ MODE

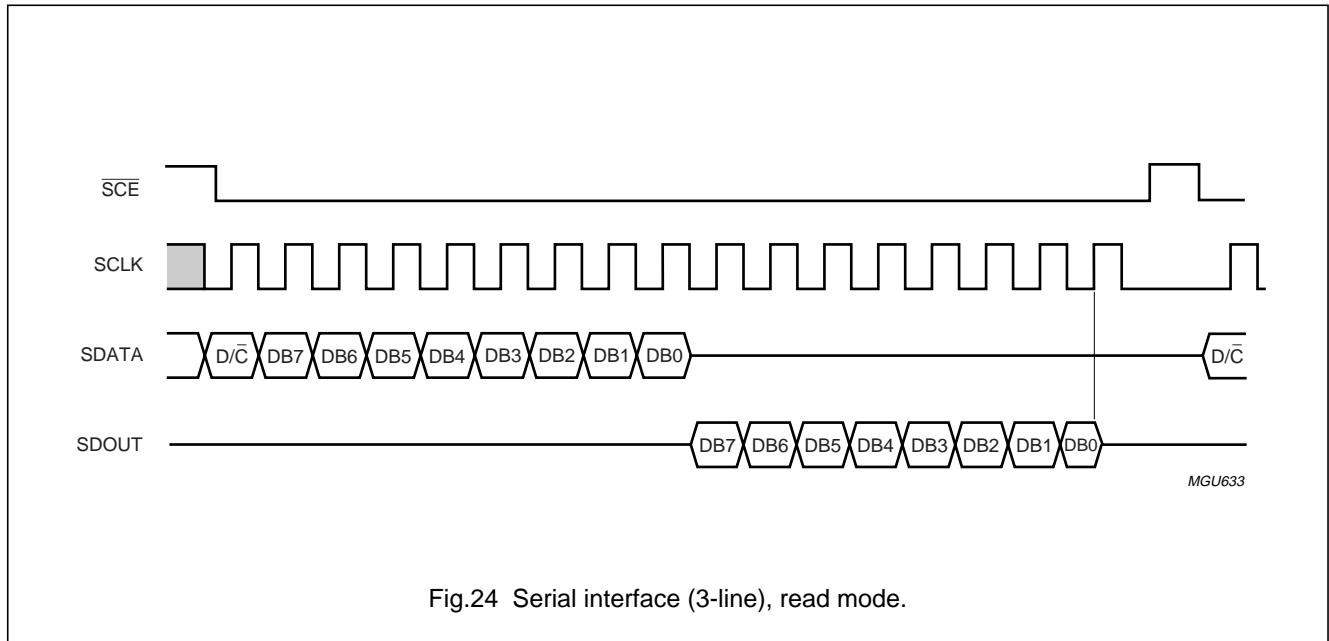

Fig.24 Serial interface (3-line), read mode.

In the read mode of the interface, that the microcontroller reads data from the PCF8813. To do this the microcontroller has first to send a command, then the read status command, and then the PCF8813 will respond by transmitting data on the SDOUT line. After that, \overline{SCE} is required to go HIGH before a new command is sent (see Fig.24).

The PCF8813 samples the SDATA data at rising SCLK edges, but shifts SDOUT data at falling SCLK edges. Thus the microcontroller reads SDOUT data at rising SCLK edges.

After the read status command has been sent, the SDATA line must be set to 3-state not later than at the falling SCLK edge of the last bit.

The 8th read bit is shorter than the others because it is terminated by the rising SCLK edge (see Fig.24). The last rising SCLK edge sets SDOUT to 3-state after a delay time (see time t_4 in Fig.44).

(67 + 1) × 102 pixels matrix LCD driver

PCF8813

10 I²C-BUS INTERFACE (Hs-MODE)

10.1 Characteristics of the I²C-bus (Hs-mode)

The I²C-bus Hs-mode is for bidirectional, two-line communication between different ICs or modules with speeds up to 3.4 MHz. The only difference between Hs-mode slave devices and Fast-mode slave devices is the speed at which they operate, therefore the buffers on the SLCH and SDAH outputs⁽¹⁾ have an open-drain. This is the same for I²C-bus master devices which have an open-drain SDAH output and a combination of open-drain pull-down and current source pull-up circuits on the SCLH output. Only the current source of one master is enabled at any one time, and only during Hs-mode. Both lines must be connected to a positive supply via a pull-up resistor.

Data transfer may be initiated only when the bus is not busy.

(1) In Hs-mode, SCL and SDA lines operating at the higher frequency are referred to as SCLH and SDAH.

10.1.1 SYSTEM CONFIGURATION

- Transmitter: the device that sends the data to the bus
- Receiver: the device that receives the data from the bus
- Master: the device which initiates a transfer, generates clock signals and terminates a transfer
- Slave: the device addressed by a master
- Multi-master: more than one master can attempt to control the bus at the same time without corrupting the message
- Arbitration: procedure to ensure that, if more than one master simultaneously tries to control the bus, only one is allowed to do so and the message is not corrupted
- Synchronisation: procedure to synchronize the clock signals of two or more devices.

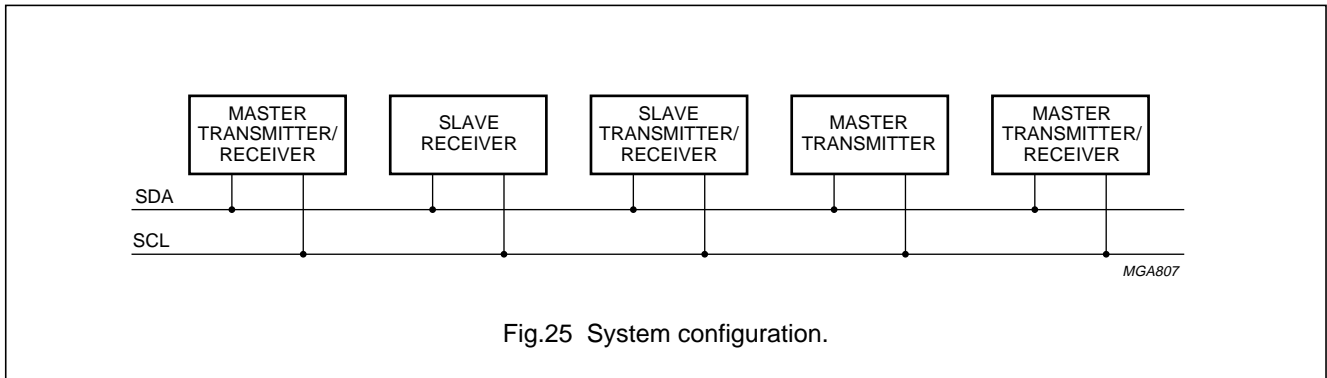

Fig.25 System configuration.

10.1.2 BIT TRANSFER

One data bit is transferred during each clock pulse (see Fig.26). The data on the SDAH line must remain stable

during the HIGH period of the clock pulse as changes in the data line at this time will be interpreted as control signals.

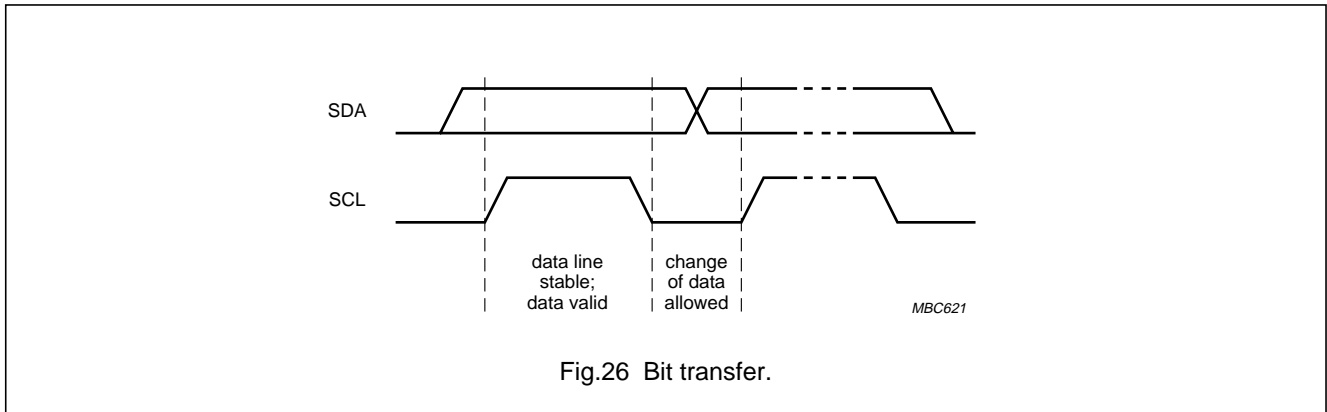

Fig.26 Bit transfer.

(67 + 1) × 102 pixels matrix LCD driver

PCF8813

10.1.3 START AND STOP CONDITIONS

Both data and clock lines remain HIGH when the bus is not busy (see Fig.27). A HIGH-to-LOW transition of the data

line, while the clock is HIGH is defined as the START condition (S). A LOW-to-HIGH transition of the data line while the clock is HIGH is defined as the STOP condition (P).

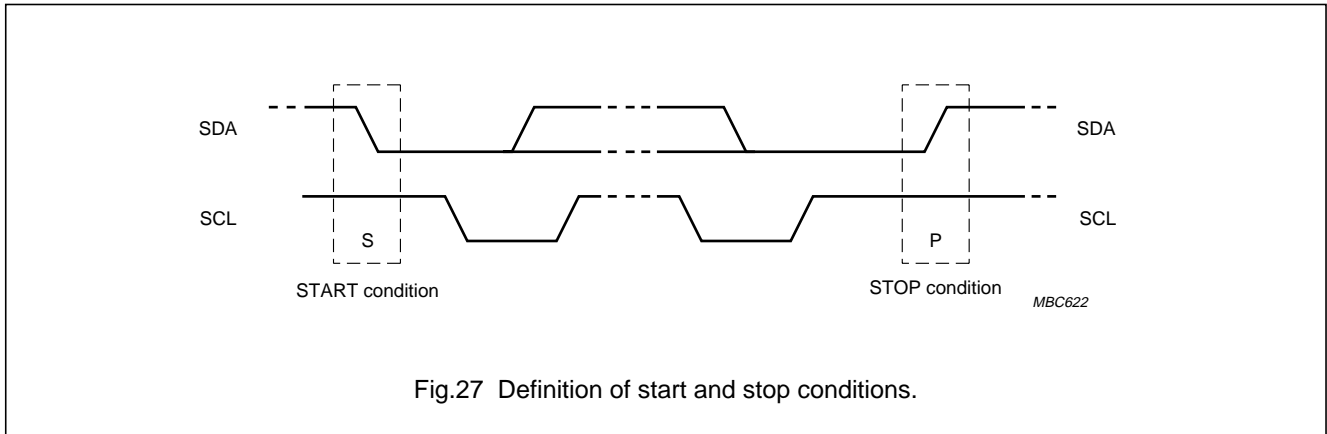

Fig.27 Definition of start and stop conditions.

10.1.4 ACKNOWLEDGE

Each byte of eight bits is followed by an acknowledge bit (see Fig.28). The acknowledge bit is a HIGH signal put on the bus by the transmitter during which time the master generates an extra acknowledge related clock pulse. A slave receiver which is addressed must generate an acknowledge after the reception of each byte. Also a master receiver must generate an acknowledge after the reception of each byte that has been clocked out of the

slave transmitter. The device that acknowledges must pull-down the SDA line during the acknowledge clock pulse, so that the SDA line is stable LOW during the HIGH period of the acknowledge related clock pulse (set-up and hold times must be taken into consideration). A master receiver must signal an end of data to the transmitter by not generating an acknowledge on the last byte that has been clocked out of the slave. In this event the transmitter must leave the data line HIGH to enable the master to generate a STOP condition.

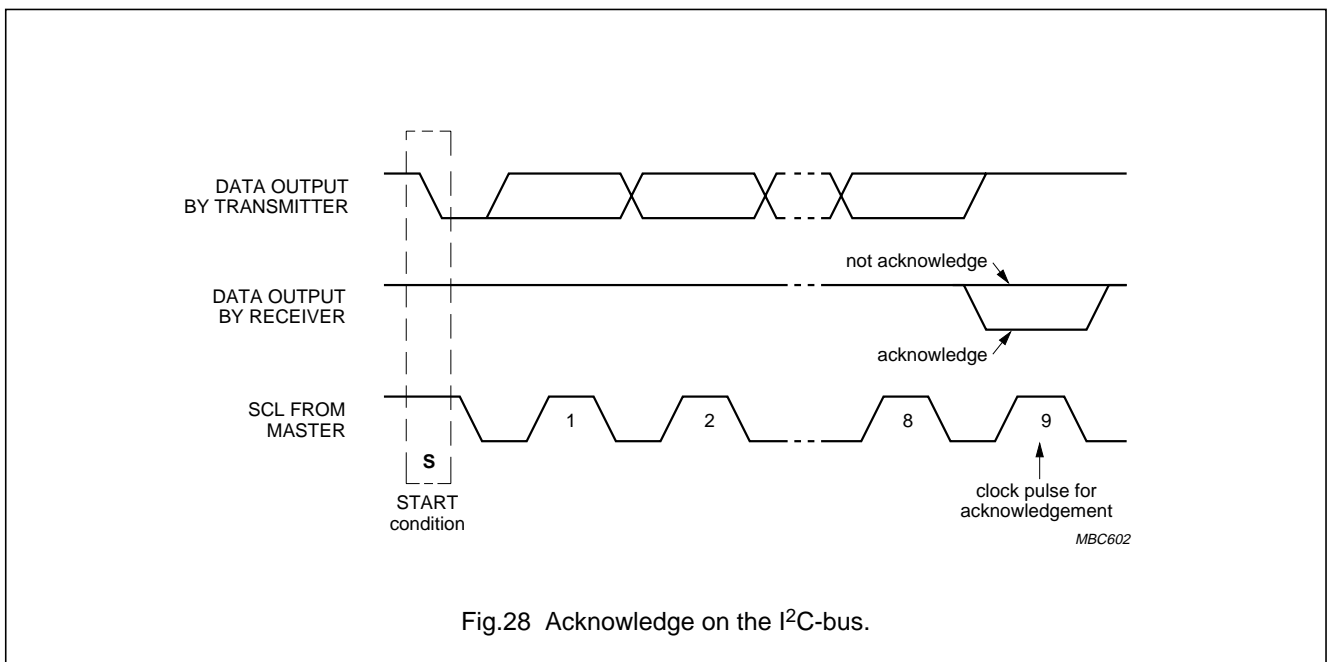

Fig.28 Acknowledge on the I²C-bus.

(67 + 1) × 102 pixels matrix LCD driver

PCF8813

10.2 I²C-bus Hs-mode protocol

The PCF8813 is a slave receiver/transmitter. If data is to be read from the device the SDAH pad must be connected, otherwise SDAHOUT may be unused.

Hs-mode can only commence after the following conditions:

- START condition (S)
- 8-bit master code (00001XXX)
- Not-acknowledge bit (\bar{A}).

The master code has two functions, as shown in Figs 29 and 30, it allows arbitration and synchronization between competing masters at Fast-mode speeds, resulting in one winner. Also the master code indicates the beginning of an Hs-mode transfer.

As no device is allowed to acknowledge the master code, the master code is followed by a not-acknowledge (\bar{A}). After this \bar{A} -bit, and the SCLH line has been pulled up to a HIGH level, the active master switches to Hs-mode and enables at t_{H} the current-source pull-up circuit for the SCLH signal (see Fig.30).

The active master will then send a repeated START condition (Sr) followed by a 7-bit slave address with a R/\bar{W} -bit, and receives an acknowledge bit (A) from the

selected slave. After each acknowledge bit (A) or not-acknowledge bit (\bar{A}) the active master disables its current-source pull-up circuit. The active master re-enables its current source again when all devices have released and the SCLH signal reaches a HIGH level. The rising of the SCLH is done by a resistor pull-up and so slower, the last part of the SCLH rise time is speeded up because the current-source is enabled. Data transfer only switches back to Fast-mode after a STOP condition (P).

A write sequence after the Hs-mode is selected is given in Fig.29. The sequence is initiated with a START condition (S) from the I²C-bus master which is followed by the slave address. All slaves with the corresponding address acknowledge in parallel, all the others will ignore the I²C-bus transfer.

After acknowledgement of a write (W) cycle, one or more command words follow which define the status of the addressed slaves. A command word consists of a control byte, which defines CO and D/ \bar{C} , plus a data byte (see Fig.31 and Table 4).

The last control byte is tagged with a cleared most significant bit, the continuation bit Co. The control and data bytes are also acknowledged by all addressed slaves on the bus.

Table 4 CO and D/ \bar{C} definition

BIT	0/1	R/W	ACTION
CO	0	N/A	last control byte to be sent; only a stream of data bytes are allowed to follow; this stream may only be terminated by a STOP or RE-START condition
	1		another control byte will follow the data byte unless a STOP or RE-START condition is received
D/ \bar{C}	0	0	data byte will be decoded and used to set-up the device
		1	data byte will return the status byte
	1	0	data byte will be stored in the display RAM
		1	RAM read back is not supported

After the last control byte, depending on the D/ \bar{C} bit setting, a series of display data bytes or command data bytes may follow. If the D/ \bar{C} -bit was set to logic 1, these display bytes are stored in the display RAM at the address specified by the data pointer. The data pointer is updated automatically and the data is directed to the intended PCF8813. If the D/ \bar{C} -bit of the last control byte was set to logic 0, these command bytes will be decoded and the setting of the device will be changed according to the received commands. The acknowledgement after each byte is made only by the addressed PCF8813. At the end of the transmission the I²C-bus master issues a STOP

condition (P) and switches back to Fast-mode, however, to reduce the overhead of the master code, its possible that a master links a number of Hs-mode transfers, separated by repeated START conditions (Sr).

A read sequence (see Fig.32) follows after the Hs-mode is selected. The PCF8813 will immediately start to output the requested data until a NOT acknowledge is transmitted by the master. Before the read access, the user has to set the D/ \bar{C} -bit to the appropriate value by a preceding write access. The write access should be terminated by a RE-START condition so that the HS-mode is not disabled.

(67 + 1) × 102 pixels matrix LCD driver

PCF8813

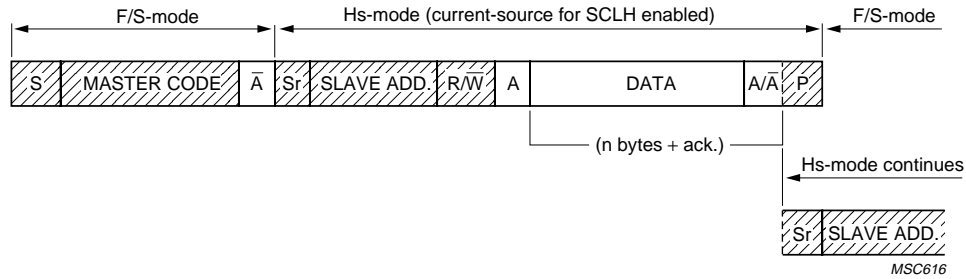

Fig.29 Data transfer format in Hs-mode.

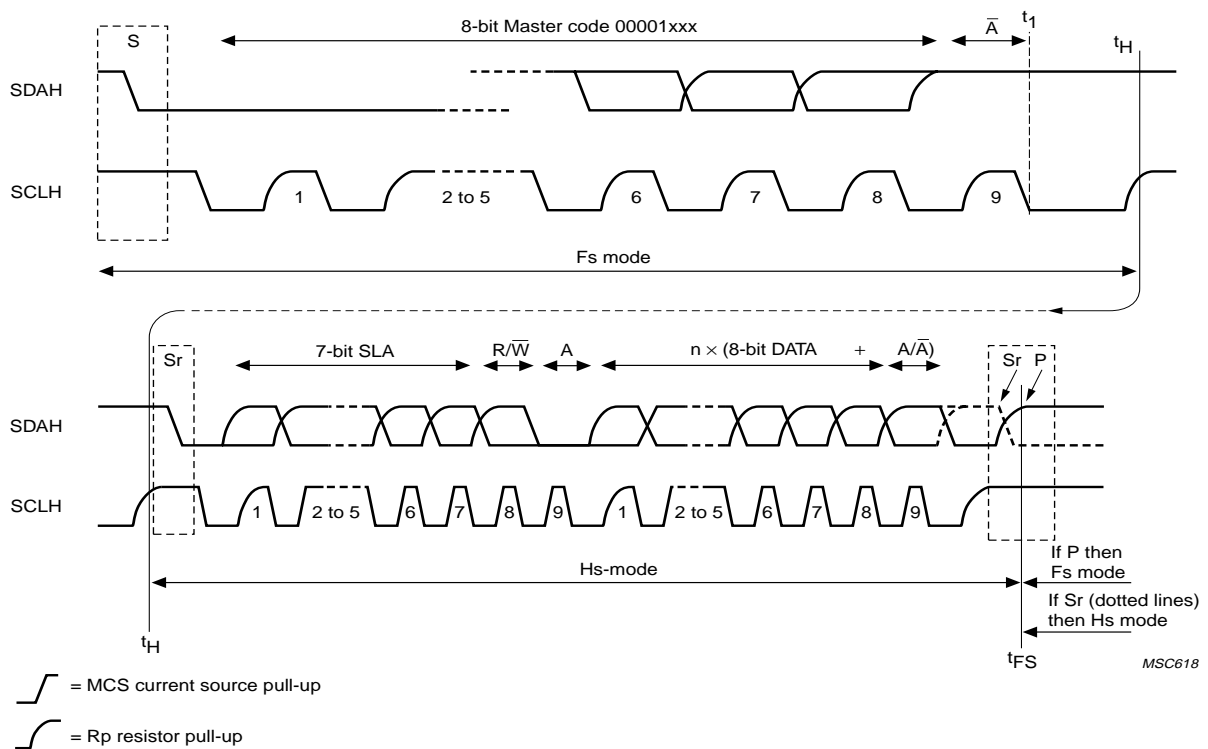

Fig.30 Complete data transfer in Hs-mode.

(67 + 1) × 102 pixels matrix LCD driver

PCF8813

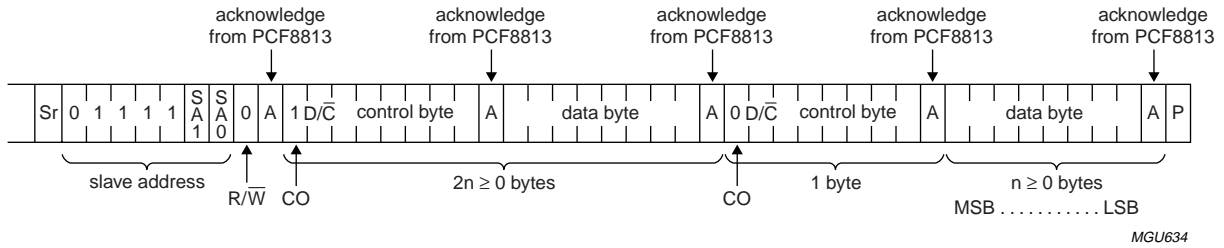

Fig.31 Master transmits in Hs-mode to slave receiver; write mode.

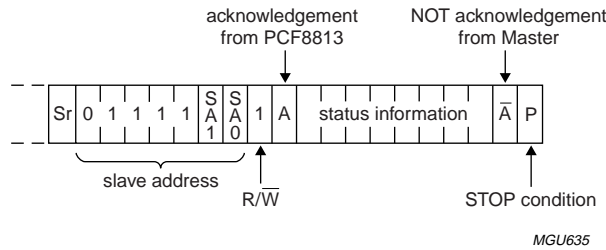

Fig.32 Master receives from slave transmitter (status register is read); read mode.

10.3 Command decoder

The command decoder identifies command words that arrive on the I²C-bus.

- Pairs of bytes
 - first byte determines whether information is display or instruction data
 - second byte contains information.
- Stream of information bytes after CO = 0; display or instruction data depending on last D/C-bar-bit.

The most significant bit of a control byte is the continuation bit CO. If this bit is logic 1, it indicates that only one data byte, either command or RAM data, will follow. If the bit is logic 0, it indicates that a series of data bytes, either command or RAM data, may follow. The DB6 bit of a control byte is the RAM data/command bit D/C-bar. When this bit is logic 1, it indicates that a RAM data byte will be transferred next. If the bit is at logic 0, it indicates that a command byte will be transferred next.

(67 + 1) × 102 pixels matrix LCD driver**PCF8813****11 INSTRUCTIONS**

The PCF8813 interfaces via the 8-bit parallel interface, two different 3-line serial interfaces, 4-wire serial interface or an I²C-bus interface. Processing of the instructions does not require the display clock.

In the case of the parallel and 4-wire serial interface, data accesses to the PCF8813 can be divided into two areas; those that define the operating mode of the device, and those that fill the display RAM; the distinction being the D/C input. When the D/C input is set to logic 0, the chip will respond to instructions as defined in Table 5. When the D/C bit is at logic 1, the chip will send data into the RAM.

When the 3-wire serial interface or the I²C-bus interface is used, the distinction between instructions that define the

operating mode of the device and those that fill the display RAM is made respectively by the display data length instruction (4-line SPI) or by D/C bit in the data stream (3-line serial interface and I²C-bus interface).

There are four types of instructions:

- Defining PCF8813 functions such as display configuration, etc.
- Setting internal RAM addresses
- Performing data transfer with internal RAM
- Other instructions.

In normal use, category 3 instructions are used most frequently. To lessen the MPU program load, automatic incrementing by one of the internal RAM address pointers after each data write is implemented.

Table 5 Instruction set

Instructions not expressly defined in this table and reserved instructions are not allowed in PCF8813 applications.

INSTRUCTION	D/C	R/W	COMMAND BYTE								DESCRIPTION
			DB7 (MSB)	DB6	DB5	DB4	DB3	DB2	DB1	DB0 (LSB)	
H = 0 or 1											
NOP	0	0	0	0	0	0	0	0	0	0	no operation
Function set	0	0	0	0	1	MX	MY	PD	V	H	Power-down control; entry mode
Read status byte	0	1	0	0	0	1	1	0	δ ⁽¹⁾	δ ⁽¹⁾	read status byte for serial and I ² C-bus interfaces
Read status byte	0	1	BUSY	DON	RES	MF2	MF1	MF0	DS1	DS0	reads parallel interface status byte
Write data	1	0	D7	D6	D5	D4	D3	D2	D1	D0	writes data to RAM
H = 0											
Reserved	0	0	0	0	0	0	0	1	X	X	do not use
Display control	0	0	0	0	0	0	1	D	0	E	sets display configuration
Set lower/higher program range	0	0	0	0	0	1	0	0	0	PRS	V _{LCD} programming range
Set power control HVgen on/off	0	0	0	0	0	1	0	0	1	PC	switch HVgen on/off
Display configuration	0	0	0	0	0	1	0	1	1	δ ⁽¹⁾	double command byte: set data order; top/bottom row swap mode
	0	0	0	0	0	0	0	D0	0	BRS	

$(67 + 1) \times 102$ pixels matrix LCD driver

PCF8813

INSTRUCTION	D/C	R/W	COMMAND BYTE								DESCRIPTION
			DB7 (MSB)	DB6	DB5	DB4	DB3	DB2	DB1	DB0 (LSB)	
Set display data length	0	0	0	1	1	1	$\delta^{(1)}$	$\delta^{(1)}$	$\delta^{(1)}$	$\delta^{(1)}$	double command byte; set display data length, only used in 3-line SPI
	0	0	0	D6	D5	D4	D3	D2	D1	D0	
Set Y address of RAM	0	0	0	1	0	0	Y_3	Y_2	Y_1	Y_0	sets Y address of RAM: $0 \leq Y \leq 9$
Set maximum Y address	0	0	0	1	0	1	$\delta^{(1)}$	$\delta^{(1)}$	$\delta^{(1)}$	$\delta^{(1)}$	double command byte: set maximum Y: $0 \leq Y \leq 8$
	0	0	0	0	0	0	$Y_{\max 3}$	$Y_{\max 2}$	$Y_{\max 1}$	$Y_{\max 0}$	
Set maximum X address	0	0	0	1	1	0	$\delta^{(1)}$	$\delta^{(1)}$	$\delta^{(1)}$	$\delta^{(1)}$	double command byte: set maximum X: $0 \leq X \leq 101$
	0	0	0	$X_{\max 6}$	$X_{\max 5}$	$X_{\max 4}$	$X_{\max 3}$	$X_{\max 2}$	$X_{\max 1}$	$X_{\max 0}$	
Set X address of RAM	0	0	1	X_6	X_5	X_4	X_3	X_2	X_1	X_0	sets X address of RAM: $0 \leq X \leq 101$
H = 1											
Reserved	0	0	0	0	0	0	0	0	0	1	
Reserved	0	0	0	0	0	0	0	0	1	X	
Temperature compensation	0	0	0	0	0	0	0	1	TC_1	TC_0	set temperature coefficient (TCx)
Set HVgen stages	0	0	0	0	0	0	1	0	S_1	S_0	set multiplication factor
Bias system	0	0	0	0	0	1	0	BS_2	BS_1	BS_0	set bias system (BSx)
Reserved	0	0	0	1	1	0	0	$\delta^{(1)}$	$\delta^{(1)}$	$\delta^{(1)}$	double command byte: do not use
	0	0	0	0	0	0	$\delta^{(1)}$	$\delta^{(1)}$	$\delta^{(1)}$	$\delta^{(1)}$	
Normal or partial display mode	0	0	0	1	0	1	0	$\delta^{(1)}$	$\delta^{(1)}$	$\delta^{(1)}$	double command byte: set normal or partial display mode
	0	0	0	0	0	0	0	0	0	N/\bar{P}	
Free programmable MUX rate	0	0	0	1	1	0	1	$\delta^{(1)}$	$\delta^{(1)}$	$\delta^{(1)}$	double command byte: set mask register for FPMR mode (1 : 9, 17, and 25 to 64)
	0	0	M_7	M_6	M_5	M_4	M_3	M_2	M_1	M_0	
Set initial row to be displayed	0	0	0	1	0	0	1	$\delta^{(1)}$	$\delta^{(1)}$	$\delta^{(1)}$	double command byte: set start row $0 \leq X \leq 66$
	0	0	0	C_6	C_5	C_4	C_3	C_2	C_1	C_0	
Set RAM line address for initial row	0	0	0	1	0	1	1	$\delta^{(1)}$	$\delta^{(1)}$	$\delta^{(1)}$	double command byte; sets RAM line address to be displayed $0 \leq L \leq 66$
	0	0	0	L_6	L_5	L_4	L_3	L_2	L_1	L_0	

$(67 + 1) \times 102$ pixels matrix LCD driver

PCF8813

INSTRUCTION	D/C	R/W	COMMAND BYTE								DESCRIPTION
			DB7 (MSB)	DB6	DB5	DB4	DB3	DB2	DB1	DB0 (LSB)	
Disable OTP circuitry	0	0	0	0	0	1	1	1	0	0	disable OTP circuitry
Enter module maker calibration mode	0	0	0	0	0	1	1	1	1	0	module maker calibration
Software reset	0	0	0	1	1	1	0	0	0	1	enable software reset
Set V_{PR}	0	0	1	V_{PR6}	V_{PR5}	V_{PR4}	V_{PR3}	V_{PR2}	V_{PR1}	V_{PR0}	write V_{PR} to register

Note

1. δ = don't care.

Table 6 Explanation of mnemonics used in Table 5

BIT	0	1	RESET STATE
PD	chip active	chip is in Power-down mode	1
H	basic command set	extended command set	0
V	horizontal addressing	vertical addressing	0
PC	power control off	power control on	1
MX	normal X addressing	X address is mirrored	0
MY	display is not vertically mirrored	display is vertically mirrored	0
TRS	top rows are not mirrored	top rows are mirrored	0
BRS	bottom rows are not mirrored	bottom rows are mirrored	0
DO	LSB is on top	MSB is on top	1
PRS	V_{LCD} programming range LOW	V_{LCD} programming range HIGH	0
N/P	partial display driving mode	normal display driving mode	1
C[6:0]	sets the initial R0 of the display.; this command cannot access R67 (icon row)		0000000
L[6:0]	sets the line address of the display RAM to be displayed on the initial R0; this command cannot access R67		0000000
$Y_{max}[3:0]$	sets maximum Y address for wraparound		1000
$X_{max}[6:0]$	sets the maximum X address		1100101
D, E	display control; see Table 8		00
TC[1:0]	set temperature coefficient; see Table 9		00
S[1:0]	set voltage multiplication factor; see Table 10		00
BS[2:0]	bias system		000
$V_{PR}[6:0]$	V_{LCD} programming		0000000
M[7:0]	set partial display (full display = 11111111)		11111111

$(67 + 1) \times 102$ pixels matrix LCD driver

PCF8813

Table 7 Read status byte

BIT	FUNCTION
BUSY	0 = chip is able to accept new commands; 1 = chip is unable to accept new commands
DON	0 = display OFF; 1 = display ON
$\overline{\text{RES}}$	0 = reset NOT in progress; 1 = reset in progress
MF[2:0]	manufacturer identification bits
DS[1:0]	device recognition; currently has a fixed value of 00 (recognition bits for a driver with 64 to 67 rows)

Table 8 Display control; bits D and E

D	E	FUNCTION
0	0	display blank
1	0	normal mode
0	1	all display segments on
1	1	inverse video mode

Table 9 Set temperature coefficient; bits TC[1:0]

TC ₁	TC ₀	FUNCTION
0	0	V _{LCD} temperature coefficient 0
0	1	V _{LCD} temperature coefficient 1
1	0	V _{LCD} temperature coefficient 2
1	1	V _{LCD} temperature coefficient 3

Table 10 Set voltage multiplication factor; bits S[1:0]

S ₁	S ₀	FUNCTION
0	0	2 × voltage multiplier
0	1	3 × voltage multiplier
1	0	4 × voltage multiplier
1	1	5 × voltage multiplier

11.1 Initialization

Immediately following Power-on, all internal registers as well as the RAM content are undefined. A $\overline{\text{RES}}$ pulse **must** be applied to the reset input.

Reset is accomplished by applying an external reset pulse (active LOW) at the pad RES. When reset occurs within the specified time all internal registers are reset, however the RAM is still undefined. The $\overline{\text{RES}}$ input must be $\leq 0.3V_{DD}$ when V_{DD} reaches $V_{DD(\text{min})}$ (or higher) within a maximum time t_{VHRL} after V_{DD} going HIGH (see Fig.37).

A reset can also be made by sending a reset command. This command can be used during normal operating but not to initialize the chip after Power-on.

11.2 Reset function

After reset the LCD driver has the following state:

- Power-down mode (PD = 1)
- Horizontal addressing (V = 0)
- Normal instruction set (H = 0)
- Display blank (D and E = 00)
- Address counter X[6:0] = 0000000 and Y[3:0] = 0000
- Temperature control mode TC[1:0] = 00
- V_{LCD} is equal to 0 and PRS = 0
- Power control is enabled (PC = 1)
- Normal row driving of display (N/ $\overline{\text{P}}$ = 1)
- Partial mode set for all rows available (M[7:0] = 11111111)
- HV generator programmed off (V_{PR}[6:0] = 0000000)
- 2 × voltage multiplier (S[1:0] = 00)
- After power-on, RAM data is undefined, the reset signal does not change the content of the RAM
- Data order DO = 0
- All LCD outputs at V_{SS} (display off)
- Bias system (BS[2:0] = 000)
- Display start line set to R0 (C[6:0] = 000000)
- RAM line address set to 0 (L[6:0] = 000000)
- Maximum X address = 101 (X_{max}[6:0] = 1100101)
- Maximum Y address = 8 (Y_{max}[3:0] = 1000)
- Display is not mirrored (MX = 0; MY = 0 and BRS = 0).

11.3 Power-down mode

Power-down mode gives the following circuit status:

- V_{LCD} discharges to V_{SS} as Power-down mode occurs
- All LCD outputs go to V_{SS} (display off)
- Bias generator and V_{LCD} generator switch-off, V_{LCD} can be disconnected
- Oscillator switches off (external clock is possible)
- RAM contents are not cleared; RAM data can be written.

(67 + 1) × 102 pixels matrix LCD driver**PCF8813****11.4 Display Control**

Bits D and E (see Table 8) select the display mode.

When bit MX = 0, the display RAM is written from left to right (X = 0 is on the left side and X = 101 is on the right side of the display). When bit MX = 1, the display RAM is written from right to left (X = 0 is on the right side and X = 101 is on the left side of the display).

The bit MX has an impact on the way the RAM is written. So if horizontal mirroring of the display is required, the RAM must first be rewritten.

When bit MY = 1, the display is mirrored vertically. A change of bit MY has an immediate effect on the display.

When bit V = 0, horizontal addressing is selected and data is written into the DDRAM as shown in Fig.5. When bit V = 1, vertical addressing is selected, then data is written into the DDRAM as shown in Fig.6.

11.5 Set Y address of RAM

Bits Y[3:0] define the Y address vector address of the display RAM.

Table 11 Range of Y address and allowable X range

Y ADDRESS				RAM CONTENT	ALLOWED X RANGE
3	2	1	0		
0	0	0	0	bank 0 (display RAM)	0 to 101
0	0	0	1	bank 1 (display RAM)	0 to 101
0	0	1	0	bank 2 (display RAM)	0 to 101
0	0	1	1	bank 3 (display RAM)	0 to 101
0	1	0	0	bank 4 (display RAM)	0 to 101
0	1	0	1	bank 5 (display RAM)	0 to 101
0	1	1	0	bank 6 (display RAM)	0 to 101
0	1	1	1	bank 7 (display RAM)	0 to 101
1	0	0	0	bank 8 (display RAM)	0 to 101
1	0	1	0	bank 10 (display RAM)	0 to 101

In bank 8 only three bits are accessed, and in bank 10 only one bit is accessed.

11.6 Set X address of RAM

The X address points to the columns. The range of X is 0 to 101 (65H).

11.7 Set maximum X address or Y address

These two commands ($X_{max}[6:0]$ and $Y_{max}[3:0]$) set the maximum address for wraparound to occur for the columns. The range of X_{max} is 0 to 101. The maximum Y address also sets the Y address for wraparound to occur. The range of Y_{max} is 0 to 8. By design, the maximum Y setting cannot access bank 10. X_{max} and Y_{max} together also define when wraparound-to-zero takes place. These two commands are effective only when writing to the RAM.

11.8 Set display start line, initial start row and row 0

Set display start line L[6:0] allows the display line address of the display RAM to be chosen. The range is from line 0 to line 66 inclusive. The RAM address line 67 is not available for this command as it is reserved for icons. This command has an effect on the mapping between the data of the RAM and the display. The L address specifies which rows of the RAM are output to which row outputs of the display. The value of the L address defines which row of the RAM will be row 0. Row 0 of the display can in turn be set by the set initial row command C[6:0].

Figure 33 shows an example of how RAM data is mapped onto the display. In this example, the L command sets the data on line 8 of the RAM to be displayed. This data is displayed on a row set by the C command (16). When L and C are set to 8 and 16 respectively, data from RAM lines 4 to 7 is displayed on display rows 12 to 15 and RAM data from lines 15 to 18 is displayed on display lines 23 to 26.

When MY is active (MY = 1), the data from Fig.33 is mapped from the RAM to the display as shown in Fig.34. Note the 'new' location of C after MY.

11.9 Set normal or partial display mode

When $N/\bar{P} = 1$, the PCF8813 can operate only as a 67 + 1 row driver operating with a 1 : 68 multiplex rate. When $N/\bar{P} = 0$, the driver is used in free programmable multiplex rate where up to eight different multiplex rates can be selected in steps of 8, depending on the mask register value M[7:0]. When the PCF8813 is operating in FPMR mode, only the first 64 rows plus the icon row are available to the user.

Table 12 Normal or partial mode display

N/P	ACTION
0	partial mode display: 65 rows available
1	normal mode display: 68 rows available

$(67 + 1) \times 102$ pixels matrix LCD driver

PCF8813

11.10 Free programmable multiplex rate

The free programmable multiplex rate concept allows the user to limit the number of rows selected to groups of eight. Any, or all of these groups of rows can be enabled or disabled. The mask register command (M[7:0]) allows the user to turn-on or turn-off blocks of eight rows.

Each mask value controls a block of eight rows, thus in partial mode the maximum number of rows available is 64 plus the icon row. A logic 1 in the mask register enables the rows available within that block of rows, and a logic 0 disables them.

The mask register causes the row counter to count eight bits and then jump to the next enabled 8-bit group. For example, if the mask register value is 00001101, then the rows available will be 0 to 7, 16 to 23, 24 to 31 and 67.

Rows 8 to 15 and 32 to 63 have been skipped. This information is also mapped to the RAM so that only the contents of active rows are displayed.

Table 13 Range of free programmable multiplex rates

MASK REGISTER	ROWS AVAILABLE
M0	R0 to R7 + icon row
M1	R8 to R15 + icon row
M2	R16 to R23 + icon row
M3	R24 to R31 + icon row
M4	R32 to R39 + icon row
M5	R40 to R47 + icon row
M6	R48 to R55 + icon row
M7	R56 to R63 + icon row

Table 14 Examples of display normal driving mode and partial display driving mode

MASK REGISTER	MASK VALUE	ROW SEQUENCE	NORMAL DISPLAY
$\overline{N/P} = 1$ (the mask value is don't care when $\overline{N/P} = 1$ because all rows are enabled)			
M0	1	0 to 7	battery status: XXX
M1	0	8 to 15	address book
M2	0	16 to 23	connection time
M3	1	24 to 31	network: YYY
M4	0	32 to 39	reception strength
M5	0	40 to 47	2 June; 15:25
M6	0	48 to 55	
M7	1	56 to 63	keyboard locked
not available in mask register		64 to 66	
not available in mask register		67 (icon row)	
$\overline{N/P} = 0$			
M0	1	0 to 7	battery status: XXX
M1	0	8 to 15	
M2	0	16 to 23	
M3	1	24 to 31	network: YYY
M4	0	32 to 39	
M5	0	40 to 47	
M6	0	48 to 55	
M7	1	56 to 63	keyboard locked
not available in mask register		67 (icon row)	

(67 + 1) × 102 pixels matrix LCD driver

PCF8813

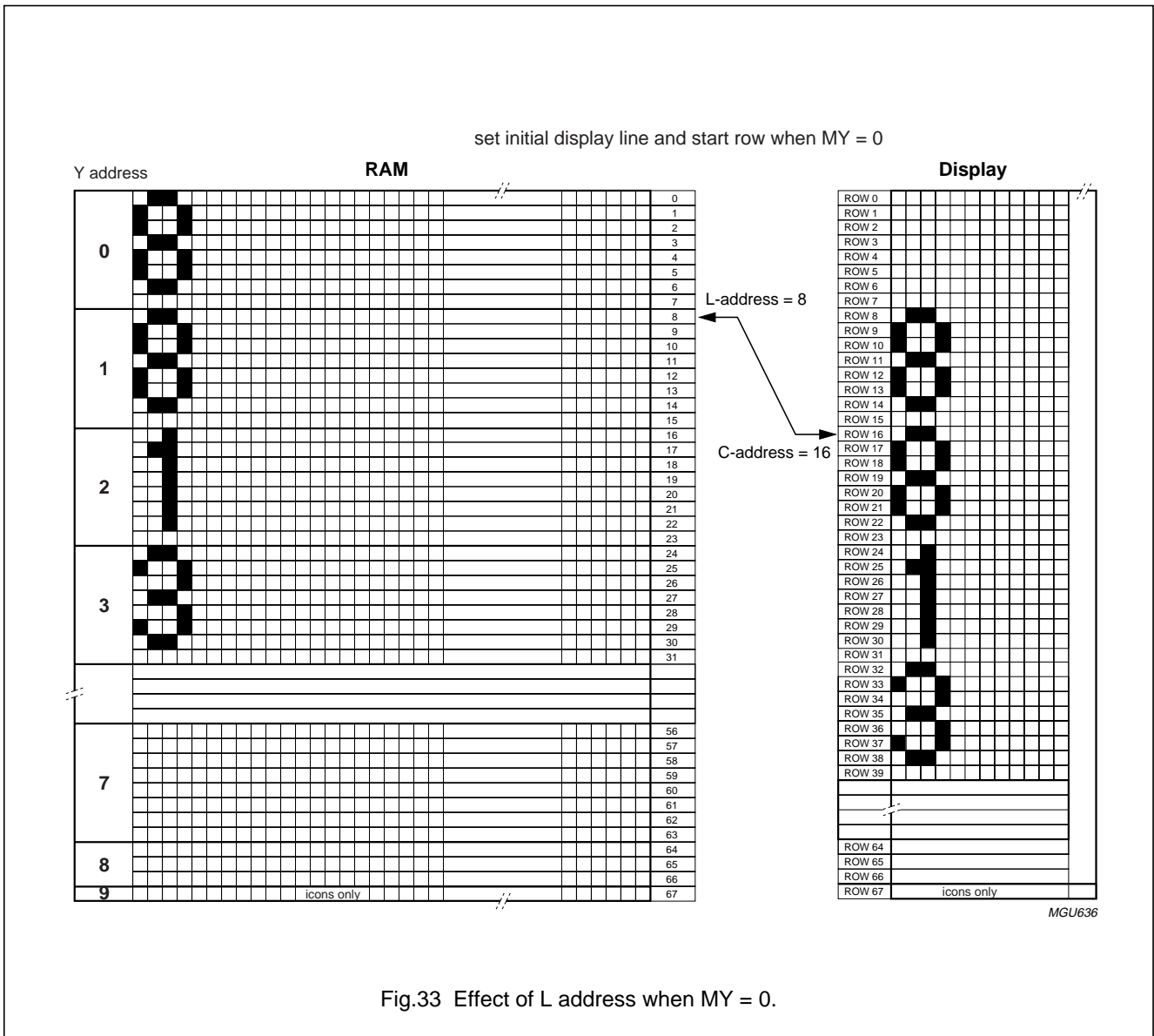

Fig.33 Effect of L address when MY = 0.

(67 + 1) × 102 pixels matrix LCD driver

PCF8813

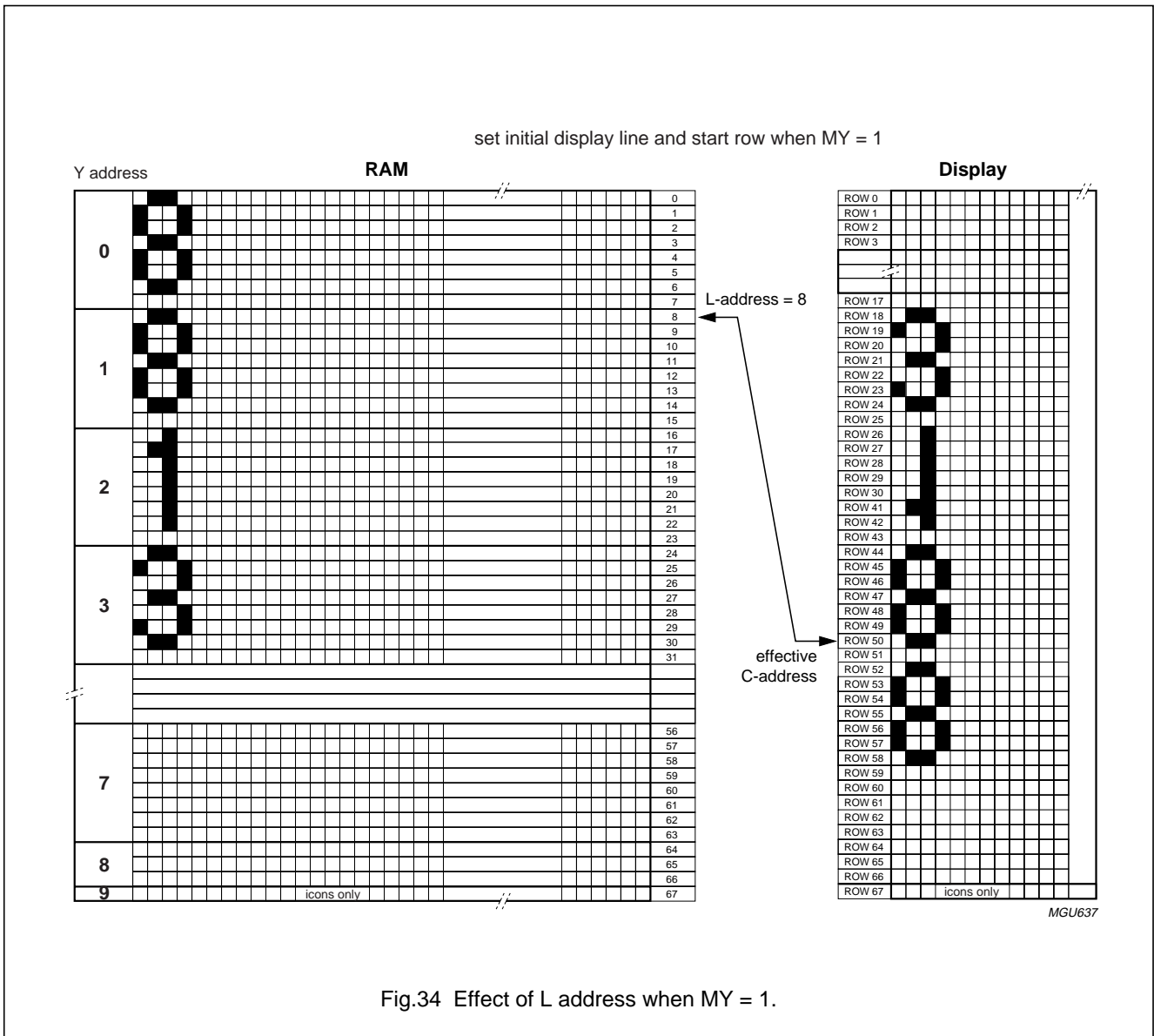

Fig.34 Effect of L address when MY = 1.

(67 + 1) × 102 pixels matrix LCD driver**PCF8813****11.11 Set HV generator stages**

The PCF8813 incorporates a software-configurable voltage multiplier. After reset (\overline{RES}) the voltage multiplier is set to $2 \times V_{DD2}$. Other voltage multiplier factors are set via the set HVgen stages command bits S[1:0].

11.12 Bias system

The bias voltage levels are set in the ratio of R - R - nR - R - R giving a $1/(n + 4)$ bias system. Different multiplex rates require different n factors. This is programmed by BS[2:0] (see Table 15).

For multiplex rates of 1 : 68 the optimum bias value n is given by: $n = \sqrt{68} - 3 = 5.246 = 5$ resulting in $1/9$ bias.

Changing the bias system from the optimum value will have a consequence for the contrast and viewing angle. One reason to depart from the optimum would be to reduce the required operating voltage. A compromise between contrast and operating voltage must be found for any particular application.

Table 15 Bias system programming

BS[2]	BS[1]	BS[0]	n	RECOMMENDED MULTIPLEX RATES
0	0	0	7	1 : 100
0	0	1	6	1 : 80
0	1	0	5	1 : 65 or 1 : 67
0	1	1	4	1 : 48
1	0	0	3	1 : 34 or 1 : 40
1	0	1	2	1 : 24
1	1	0	1	1 : 18 or 1 : 16
1	1	1	0	1 : 10, 1 : 9 or 1 : 8

Table 16 LCD bias voltage

SYMBOL	BIAS VOLTAGES	BIAS VOLTAGES FOR $1/9$ BIAS
V1	V_{LCD}	V_{LCD}
V2	$\frac{(n+3)}{(n+4)}$	$8/9 \times V_{LCD}$
V3	$\frac{(n+2)}{(n+4)}$	$7/9 \times V_{LCD}$
V4 ⁽¹⁾	$\frac{2}{(n+4)}$	$2/9 \times V_{LCD}$
V5 ⁽²⁾	$\frac{1}{(n+4)}$	$1/9 \times V_{LCD}$
V6	V_{SS}	V_{SS}

Notes

- Operation of bias level V4 is given for $V4 > V_{SS} + 0.9$ V. For higher multiplex rates, V_{LCD} has to be selected accordingly.
- For multiplex rates equal to or lower than 1 : 24 ($n = 2$) operation of the bias level V5 is limited to voltages $V5 < V_{DD2,3} - 1.1$ V. V_{LCD} has to be selected accordingly.

The operating voltage can be set by software through the interface. The binary number V_{OP} representing the operating voltage can be set according to the following formula:

$$V_{OP} = V_{CAL}[4:0] + V_{PR*}$$

Where:

V_{OP} is an 8-bit unsigned number used internally for generation of the LCD supply voltage V_{LCD}

V_{CAL} is a 5-bit twos complement number set by the module maker; see Table 17

V_{PR} is an 8-bit unsigned number composed of PRS and V_{PR*} set by an interface command.

The corresponding voltage at the reference temperature, T_{CUT} , can be calculated as:

$$V_{LCD(T_{cut})} = (a + V_{OP} \times b)$$

(67 + 1) × 102 pixels matrix LCD driver

PCF8813

The generated voltage at V_{LCD} is dependent on the temperature, programmed temperature coefficient (TC) and the programmed voltage at the reference temperature (T_{CUT}):

$$V_{LCD} = [a + V_{OP} \times b] \times [1 + TC \times (T - T_{CUT})]$$

T_{CUT} and voltages a and b for each temperature coefficient are quoted in Table 17. The maximum voltage that can be generated is dependent on the voltage of V_{DD2} and the display load current.

As the programming range for the internally generated V_{LCD} allows values above the maximum allowed V_{LCD} , the user must ensure that while setting the V_{PR}

register and selecting the temperature compensation, under all conditions and including all tolerances the V_{LCD} maximum limit of 9.0 V will never be exceeded.

For a particular liquid crystal, the optimum V_{LCD} can be calculated for a given multiplex rate. For 1 : 68, the optimum operating voltage of the liquid crystal can be calculated as;

$$V_{LCD} = \frac{1 + \sqrt{68}}{\sqrt{2} \times \left(1 - \frac{1}{\sqrt{68}}\right)} \times V_{th} = 6.98 \times V_{th}$$

where V_{th} is the threshold voltage of the liquid crystal used.

Table 17 Parameters of HV generator programming (typical values)

Nominal temperature = 27 °C; temperature coefficients calculated at nominal $V_{LCD} = 8.6$ V.

SYMBOL	PARAMETER	TC0	TC1	TC2	TC3	UNIT
a	first level V_{LCD} voltage	4.57	4.27	4.01	3.84	V
b	programmed voltage step	30.5	28.5	26.7	25.6	mV
T_{CUT}	reference temperature	27	27	27	27	°C
TC	temperature coefficient	0.00	-0.25	-0.48	-0.64	mV/K

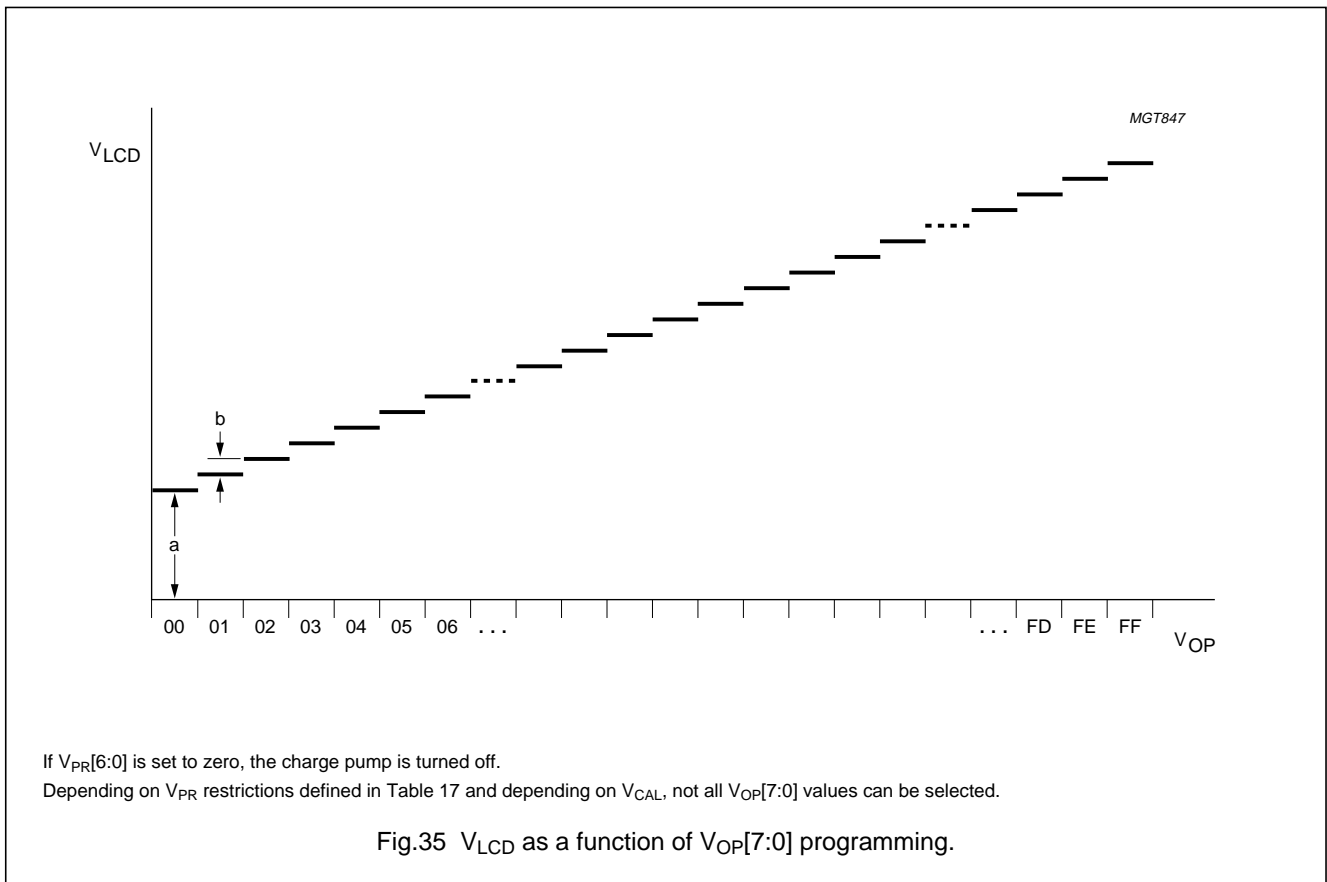

$(67 + 1) \times 102$ pixels matrix LCD driver

PCF8813

12 TEMPERATURE COMPENSATION

Due to the temperature dependency of the liquid crystal viscosity, the LCD controlling voltage V_{LCD} must be increased at lower temperatures to maintain optimum contrast. Figure 36 shows V_{LCD} for high multiplex rates. In the PCF8813 the temperature coefficient to be applied to V_{LCD} can be selected from four values by setting bits TC[1:0].

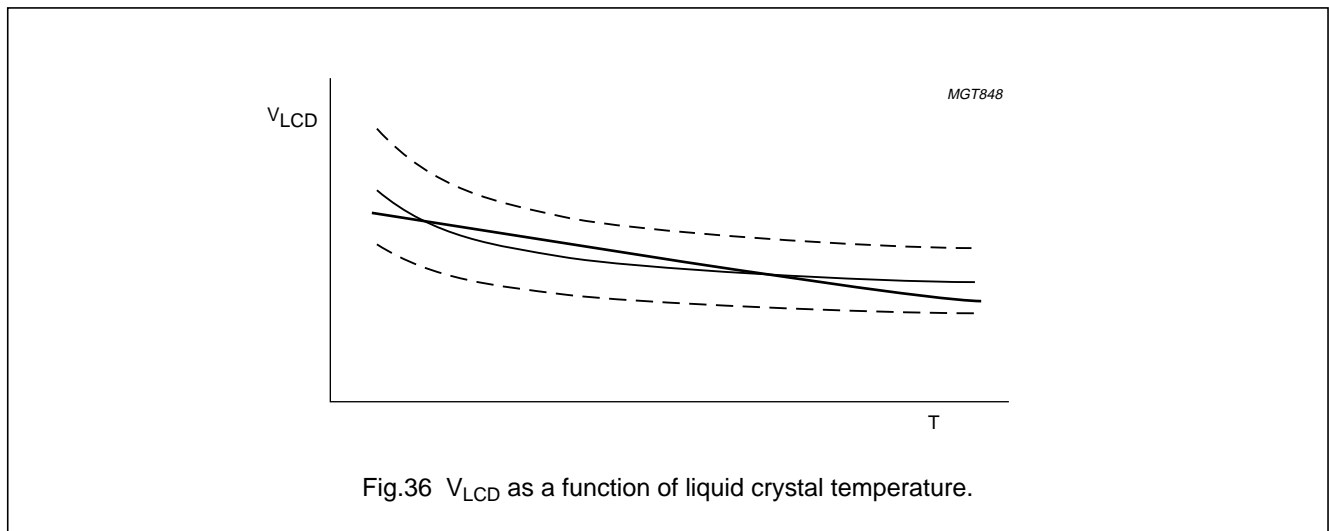
**13 LIMITING VALUES**

In accordance with the Absolute Maximum Rating System (IEC 60134); see notes 1 and 2

SYMBOL	PARAMETER	MIN.	MAX.	UNIT
V_{DD1}	supply voltage	-0.5	+6.5	V
V_{DD2}, V_{DD3}	supply voltage (voltage multiplier); see note 3	-0.5	+4.5	V
V_{LCD}	LCD supply voltage	-0.5	+9.0	V
V_I	input voltage (any pad)	-0.5	$V_{DD} + 0.5$	V
I_{SS}	ground supply current	-50	+50	mA
I_I, I_O	DC input or output current	-10	+10	mA
P_{tot}	total power dissipation	-	300	mW
P_O	power dissipation per output	-	30	mW
T_{stg}	storage temperature	-65	+150	°C
T_j	junction temperature	-	150	°C

Notes

1. Stresses above those listed under limiting values may cause permanent damage to the device.
2. Parameters are valid over operating temperature range unless otherwise specified; all voltages are with respect to V_{SS} unless otherwise specified.
3. V_{DD2} and V_{DD3} are always equal.

14 HANDLING

Inputs and outputs are protected against electrostatic discharge in normal handling. However, to be totally safe, it is desirable to take normal precautions appropriate to handling MOS devices (see "Handling MOS devices").

$(67 + 1) \times 102$ pixels matrix LCD driver

PCF8813

15 DC CHARACTERISTICS $V_{DD1} = 1.7$ to 3.3 V; $V_{SS} = 0$ V; $V_{LCD} = 3.0$ to 9.0 V; $T_{amb} = -40$ to $+85$ °C; unless otherwise specified.

SYMBOL	PARAMETER	CONDITIONS	MIN.	TYP.	MAX.	UNIT
V_{DD1}	supply voltage (logic circuits)		1.7	–	3.3	V
V_{DD2}, V_{DD3}	supply voltage (voltage multiplier)	note 1	2.4	–	4.5	V
V_{LCDIN}	LCD supply voltage input		3.0	–	9.0	V
V_{LCDOUT}	generated LCD supply voltage	note 2	4.5	–	9.0	V
$V_{LCD(tol)}$	tolerance of generated LCD supply voltage	note 3	–70	–	+70	mV
$I_{DD(tot)}$	total supply current ($I_{DD1} + I_{DD2} + I_{DD3}$)	normal mode; notes 4, 5, 6	–	100	300	μ A
		Power-down mode; note 7	–	0.5	10	μ A
I_{DD1}	supply current	external V_{LCD} ; notes 4, 6, 8	–	10	35	μ A
I_{LCD}	LCD supply current	external V_{LCD} ; notes 4, 6, 8	–	30	–	μ A
Logic circuits						
V_{OL}	LOW-level output voltage	$I_{OL} = 0.5$ mA	V_{SS}	–	$0.2V_{DD}$	V
V_{OH}	HIGH-level output voltage	$I_{OH} = -0.5$ mA	$0.8V_{DD}$	–	V_{DD}	V
V_{IL}	LOW-level input voltage		V_{SS}	–	$0.2V_{DD}$	V
V_{IH}	HIGH-level input voltage		$0.8V_{DD}$	–	V_{DD}	V
I_L	leakage current	$V_I = V_{DD}$ or V_{SS}	–1	–	+1	μ A
Column and row outputs						
R_{col}	column output resistance C0 to C101	$V_{LCD} = 7.6$ V; note 9	–	5	20	k Ω
R_{row}	row output resistance R0 to R67	$V_{LCD} = 7.6$ V; note 9	–	5	20	k Ω
$V_{col(tol)}$	bias tolerance C0 to C101	note 9	–100	0	+100	mV
$V_{row(tol)}$	bias tolerance R0 to R67	note 9	–100	0	+100	mV
LCD supply voltage generator						
TC	V_{LCD} temperature compensation	$V_{LCD(nom)} = 8.6$ V	–	0.00	–	mV/K
	temperature coefficient 0		–	–0.23	–	mV/K
	temperature coefficient 1		–	–0.48	–	mV/K
	temperature coefficient 2		–	–0.64	–	mV/K

Notes

- V_{DD2} and V_{DD3} are always equal.
- The maximum possible V_{LCD} voltage that may be generated depends on voltage, temperature and load (display).
- Valid for the temperature, V_{PR} and TC values used at calibration.
- Normal mode and internal clock.
- Conditions: $V_{DD1} = 1.8$ V; $V_{DD2} = 2.70$ V; $V_{LCD} = 7.6$ V; voltage multiplier = $4 \times V_{DD2}$; bias system $1/9$; inputs at V_{DD1} or V_{SS} ; V_{LCD} generation = internal; V_{LCD} output loaded by 10 μ A; $T_{amb} = 25$ °C.
- $f_{INTCLK} = 0$ (no data bus clock).
- Power-down mode; during Power-down all static currents are switched off.

(67 + 1) × 102 pixels matrix LCD driver**PCF8813**

8. V_{LCD} external voltage applied to V_{LCDIN} and $V_{LCDSENSE}$ inputs; V_{LCDOUT} disconnected; V_{PR} and PC set to 0 (charge pump off); display load current is not transmitted to I_{DD} .
9. Load current = 10 μ A; outputs tested one at a time.

16 AC CHARACTERISTICS

$V_{DD1} = 1.7$ to 3.3 V; $V_{SS} = 0$ V; $V_{LCD} = 3.0$ to 9.0 V; $T_{amb} = -40$ to $+85$ °C; all timings specified are based on 20% to 80% of V_{DD} with an input voltage swing of V_{SS} to V_{DD} ; unless otherwise specified.

SYMBOL	PARAMETER	CONDITIONS	MIN.	TYP.	MAX.	UNIT
f_{ext}	external clock frequency	note 1	20	38	65	kHz
f_{frame}	frame frequency	internal oscillator note 2 note 3	56 62	66 69	76 76	Hz Hz
t_{VHRL}	V_{DD} on to \overline{RES} LOW time	see Fig.37	0 ⁽⁴⁾	–	1	μ s
t_{RW}	reset pulse width LOW time	see Fig.37	500	–	–	ns
$t_{R(oper)}$	end of reset pulse to interface operational	see Fig.37	1000	–	–	ns
6800-type parallel bus; $V_{DD1} = 1.8$ to 3.3 V; see Figs 38 and 39						
t_{DCSU}	data/ $\overline{command}$ set-up time		0	–	25	ns
t_{DCHD}	data/ $\overline{command}$ hold time		0	–	–	ns
$T_{DS(cyc)}$	data strobe cycle time		1000	–	–	ns
t_{DSL}	data strobe LOW time		300	–	–	ns
t_{DSH}	data strobe HIGH time		300	–	–	ns
t_{RWSU}	read/ \overline{write} set-up time		0	–	–	ns
t_{RWHD}	read/ \overline{write} hold time		0	–	–	ns
t_{ESU}	chip enable set-up time		0	–	–	ns
t_{EHD}	chip enable hold time		0	–	–	ns
t_{DATSU}	data set-up time		80	–	–	ns
t_{DATHD}	data hold time		30	–	–	ns
$t_{DATAACC}$	output access time		–	–	280	ns
t_{DATOH}	output disable time		10	–	200	ns
8080-type parallel bus; $V_{DD1} = 1.8$ to 3.3 V; see Fig.40						
t_{DCSU}	data/ $\overline{command}$ set-up time		0	–	25	ns
t_{DCHD}	data/ $\overline{command}$ hold time		0	–	–	ns
$T_{DS(cyc)}$	data strobe cycle time		1000	–	–	ns
t_{DSLr}	data strobe LOW time (read)		120	–	–	ns
t_{DSLw}	data strobe LOW time (write)		240	–	–	ns
t_{DSHR}	data strobe HIGH time (read)		120	–	–	ns
t_{DSHW}	data strobe HIGH time (write)		120	–	–	ns
t_{DATSU}	data set-up time		80	–	–	ns
t_{DATHD}	data hold time		30	–	–	ns
$t_{DATAACC}$	output access time		–	–	280	ns
t_{DATOH}	output disable time		10	–	200	ns

$(67 + 1) \times 102$ pixels matrix LCD driver

PCF8813

SYMBOL	PARAMETER	CONDITIONS	MIN.	TYP.	MAX.	UNIT
3-line and 4-line SPI and serial interface; $V_{DD1} = 1.8$ to 3.3 V; Figs 41 to 44; note 5						
f_{SCLK}	SCLK frequency		–	–	9	MHz
T_{cyc}	SCLK cycle time		111	–	–	ns
t_{PWH1}	SCLK pulse width HIGH		45	–	–	ns
t_{PWL1}	SCLK pulse width LOW		45	–	–	ns
t_{PWH2}	\overline{SCE} minimum HIGH time		50	–	–	ns
t_{S1}	SDATA set-up time		50	–	–	ns
t_{H1}	SDATA hold time		50	–	–	ns
t_{S2}	\overline{SCE} set-up time		60	–	–	ns
t_{H2}	\overline{SCE} hold time		45	–	–	ns
t_{S3}	data/command set-up time		50	–	–	ns
t_{H3}	data/command hold time		50	–	–	ns
t_1	SDOUT access time		–	–	80	ns
t_2	SDOUT disable time	note 6	–	–	80	ns
t_3	\overline{SCE} hold time		50	–	–	ns
t_4	SDOUT disable time	note 7	–	–	80	ns
C_b	capacitive load for SDOUT	note 8	–	–	30	pF
R_b	series resistance for SDOUT	note 8	–	–	500	Ω
I²C-bus interface in Fast-mode; $V_{DD1} = 1.7$ to 3.3 V; Fig.45						
f_{SCL}	SCL clock frequency		0	–	400	kHz
t_{LOW}	SCL clock low period		1.3	–	–	μ s
t_{HIGH}	SCL clock high period		0.6	–	–	μ s
$t_{SU;DAT}$	data set-up time		100	–	–	ns
$t_{HD;DAT}$	data hold time		0	–	0.9	μ s
C_b	capacitive load represented by each bus line		–	–	400	pF
$t_{SU;STA}$	set-up time for a repeated START condition		0.6	–	–	μ s
$t_{HD;STA}$	START condition hold time		0.6	–	–	μ s
$t_{SU;STO}$	set-up time for STOP condition		0.6	–	–	μ s
t_{SP}	tolerable spike width on bus	note 9	–	–	50	ns
I²C-bus interface in Hs-mode; $V_{DD1} = 1.7$ to 3.3 V; Fig.46						
f_{SCLH}	SCLH clock frequency		0	–	3.4	MHz
$t_{SU;STA}$	set-up time (repeated) START condition		160	–	–	ns
$t_{HD;STA}$	hold time (repeated) START condition		160	–	–	ns
t_{LOW}	LOW period of the SCLH clock		160	–	–	ns
t_{HIGH}	HIGH period of the SCLH clock		60	–	–	ns
$t_{SU;DAT}$	data set-up time		10	–	–	ns

$(67 + 1) \times 102$ pixels matrix LCD driver

PCF8813

SYMBOL	PARAMETER	CONDITIONS	MIN.	TYP.	MAX.	UNIT
$t_{HD;DAT}$	data hold time		0	–	70	ns
$t_{SU;STO}$	set-up time for STOP condition		160	–	–	ns
C_b	capacitive load for SDAH and SCLH lines	total capacitance of one bus line	–	–	100	pF
	capacitive load for SDAH + SDA line and SCLH + SCL line		–	–	400	pF
t_{SP}	tolerable spike width on bus	note 9	–	–	5	ns

Notes

- $f_{frame} = \frac{f_{ext}}{n}$: (n depends on the multiplex rate, see Table 18).
- $V_{DD1} = 1.7\text{ V to }3.3\text{ V}$; $V_{SS} = 0\text{ V}$; $V_{LCD} = 3.0\text{ to }9.0\text{ V}$; $T_{amb} = -40\text{ to }+85\text{ }^\circ\text{C}$, all MUX settings.
- $V_{DD1} = 2.4\text{ V to }3.0\text{ V}$; $T_{amb} = -20\text{ }^\circ\text{C to }+70\text{ }^\circ\text{C}$; MUX = 68.
- \overline{RES} may be LOW before V_{DD} on.
- Maximum values are for $f_{SCLK} = 9\text{ MHz}$. Series resistance includes ITO track + connector resistance + printed-circuit board.
- SDOUT disable time for SPI 3-line or 4-line interface.
- SDOUT disable time for serial 3-line interface.
- Typical conditions: $V_{DD1} = 2.8\text{ V}$, $T_{amb} = 20\text{ }^\circ\text{C}$, MUX = 68; $f_{frame} = 70 \pm 3.4\text{ Hz}$.
- Inputs SDAH and SCLH are filtered and will reject spikes on the bus lines with a width of less than $t_{SW(max)}$.

Table 18 Value of n as a function of multiplex rate

MULTIPLEX RATE	n
68	483
65	462
57	464
49	500
41	504
33	476
25	468
17	505
9	500

(67 + 1) × 102 pixels matrix LCD driver

PCF8813

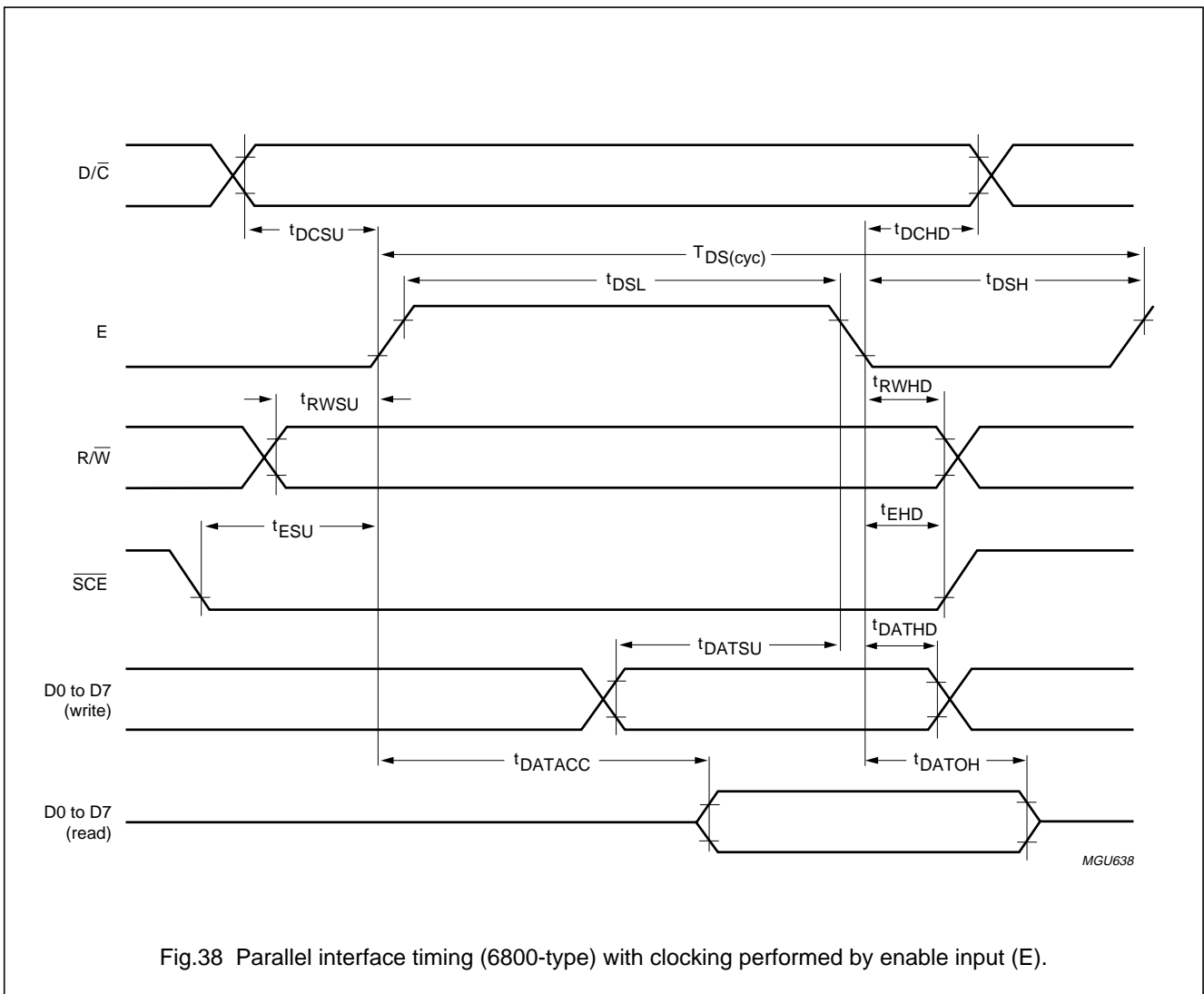
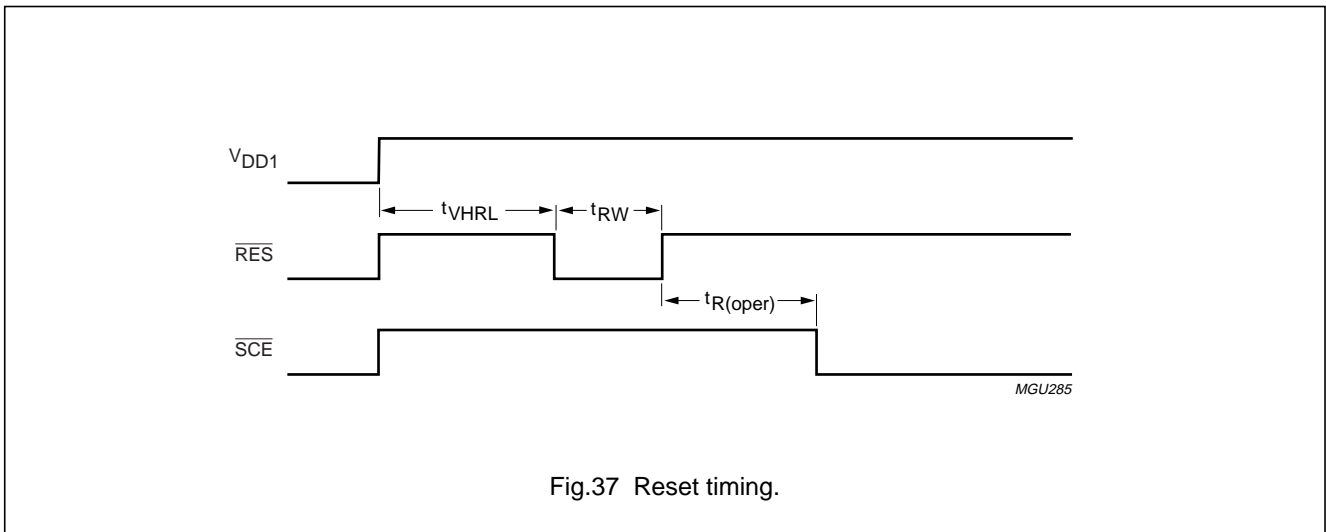

(67 + 1) × 102 pixels matrix LCD driver

PCF8813

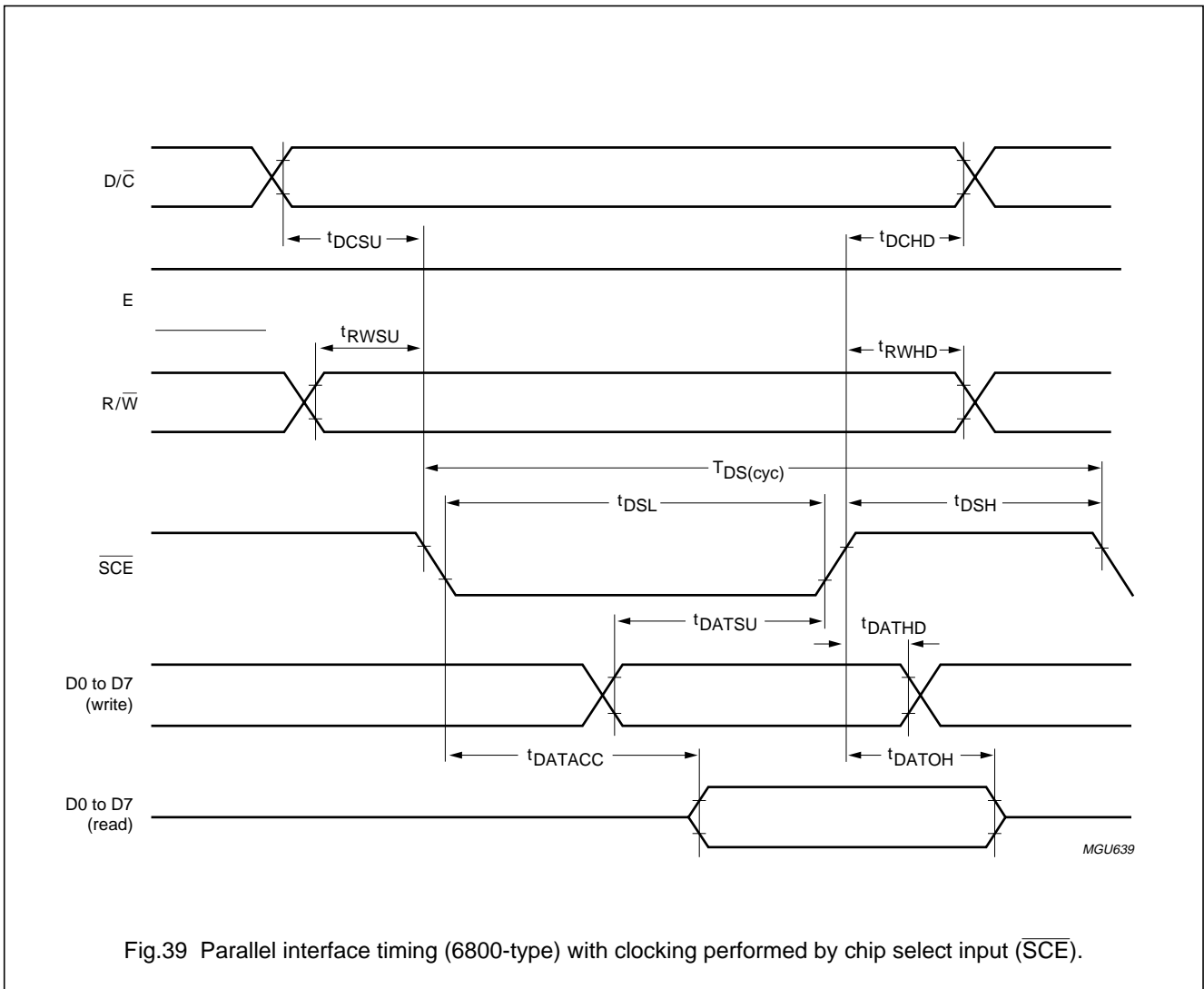

Fig.39 Parallel interface timing (6800-type) with clocking performed by chip select input (\overline{SCE}).

(67 + 1) × 102 pixels matrix LCD driver

PCF8813

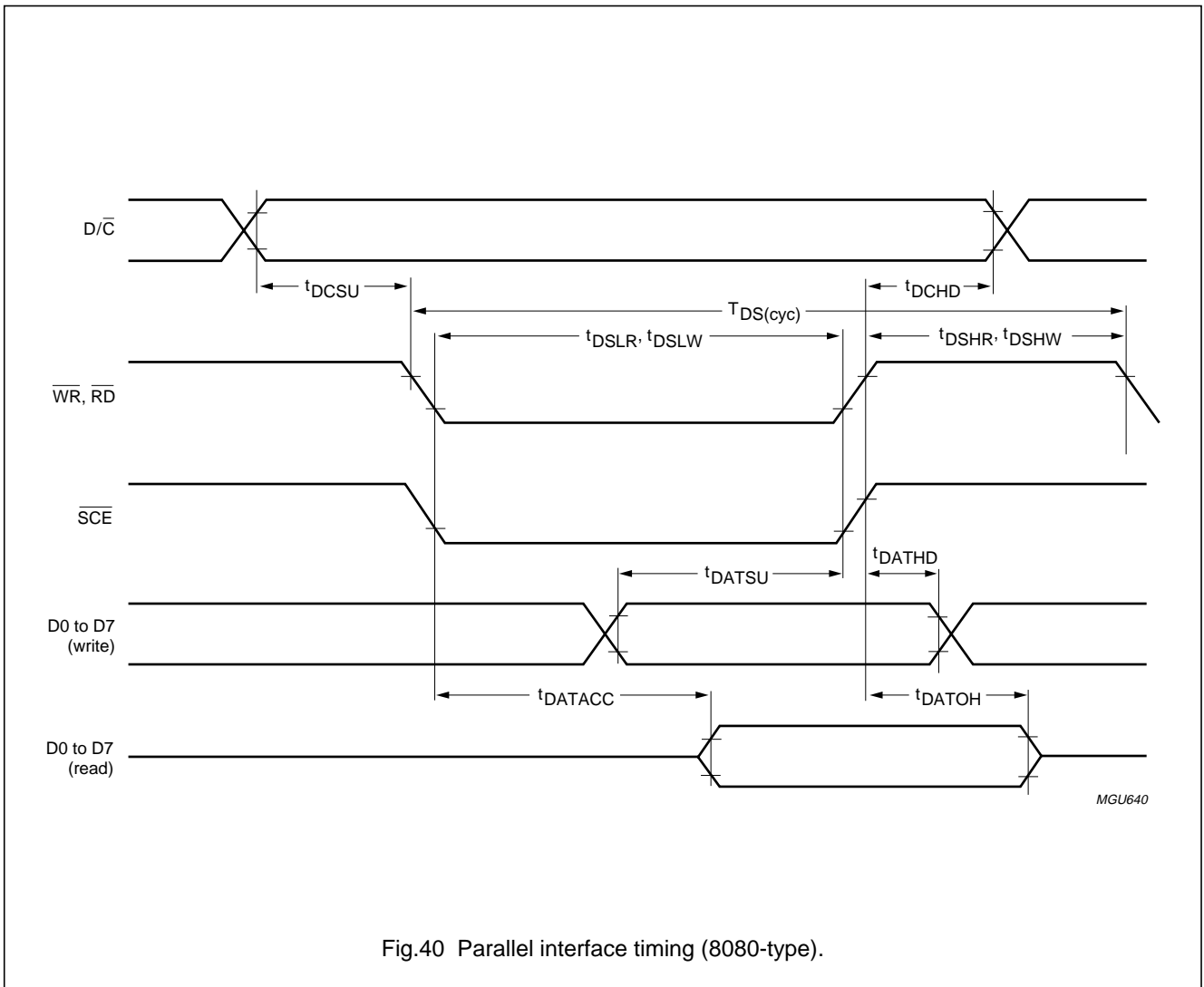

Fig.40 Parallel interface timing (8080-type).

$(67 + 1) \times 102$ pixels matrix LCD driver

PCF8813

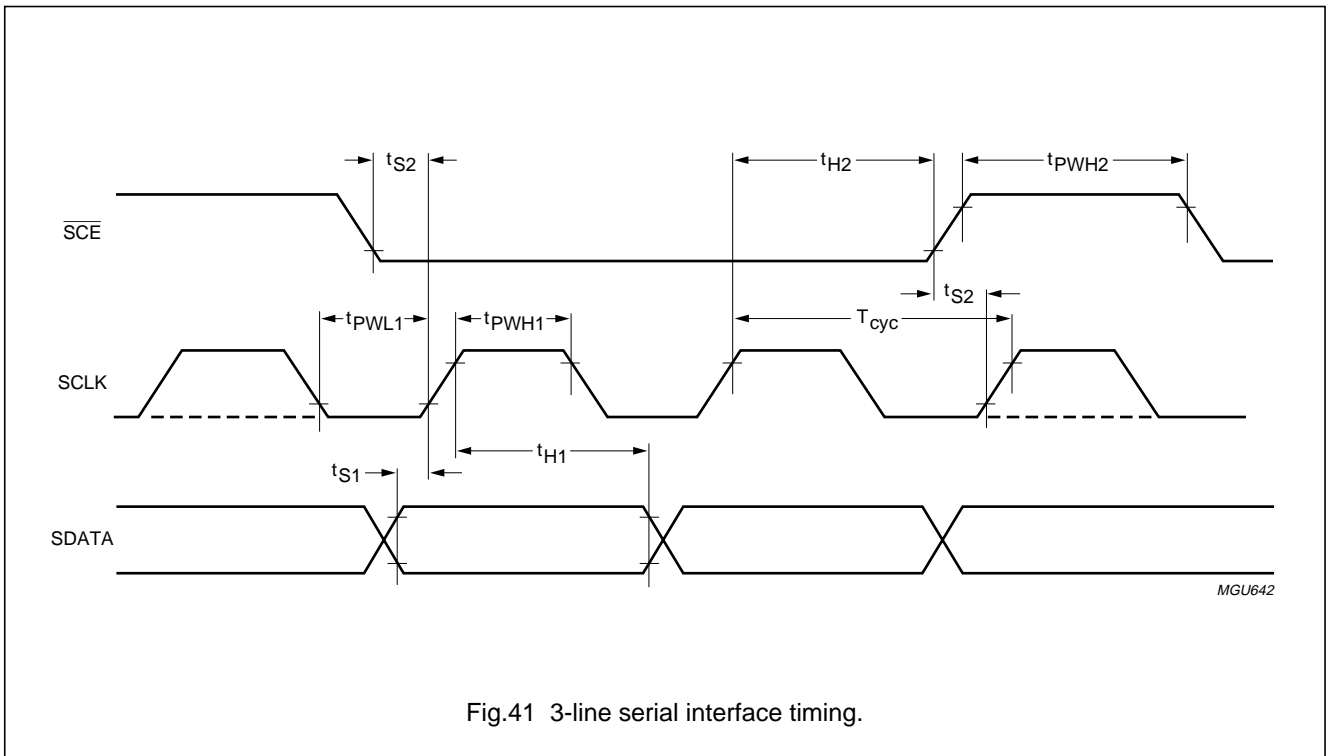

Fig.41 3-line serial interface timing.

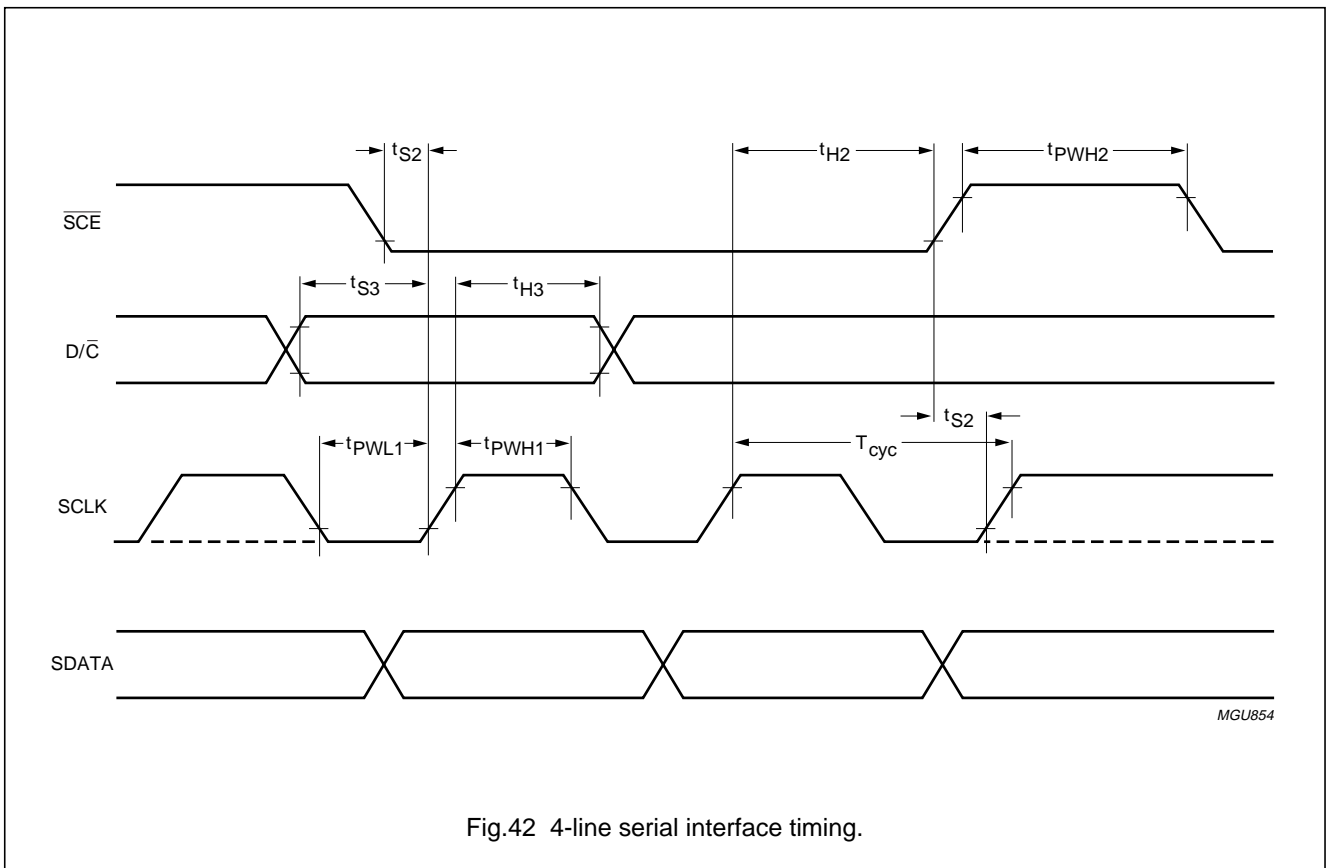
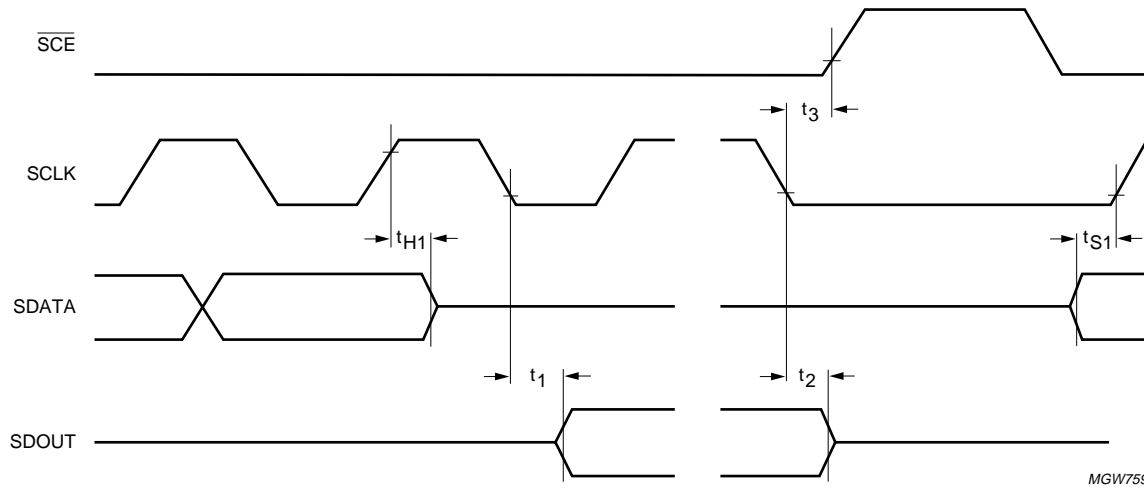

Fig.42 4-line serial interface timing.

$(67 + 1) \times 102$ pixels matrix LCD driver

PCF8813



MGW759

Fig.43 3-line and 4-line serial peripheral (SPI) interface timing (read mode).

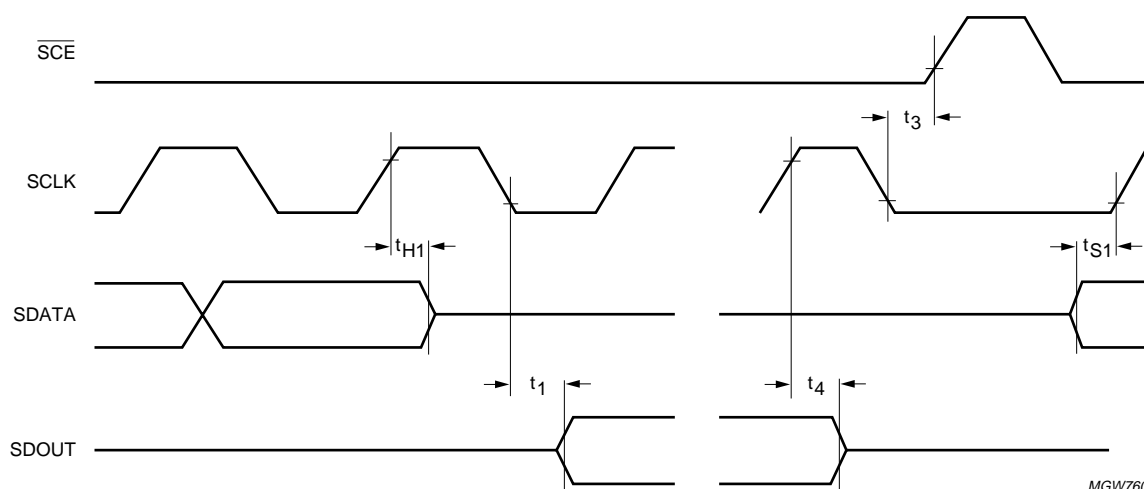

MGW760

Fig.44 3-line serial interface timing (read mode).

(67 + 1) × 102 pixels matrix LCD driver

PCF8813

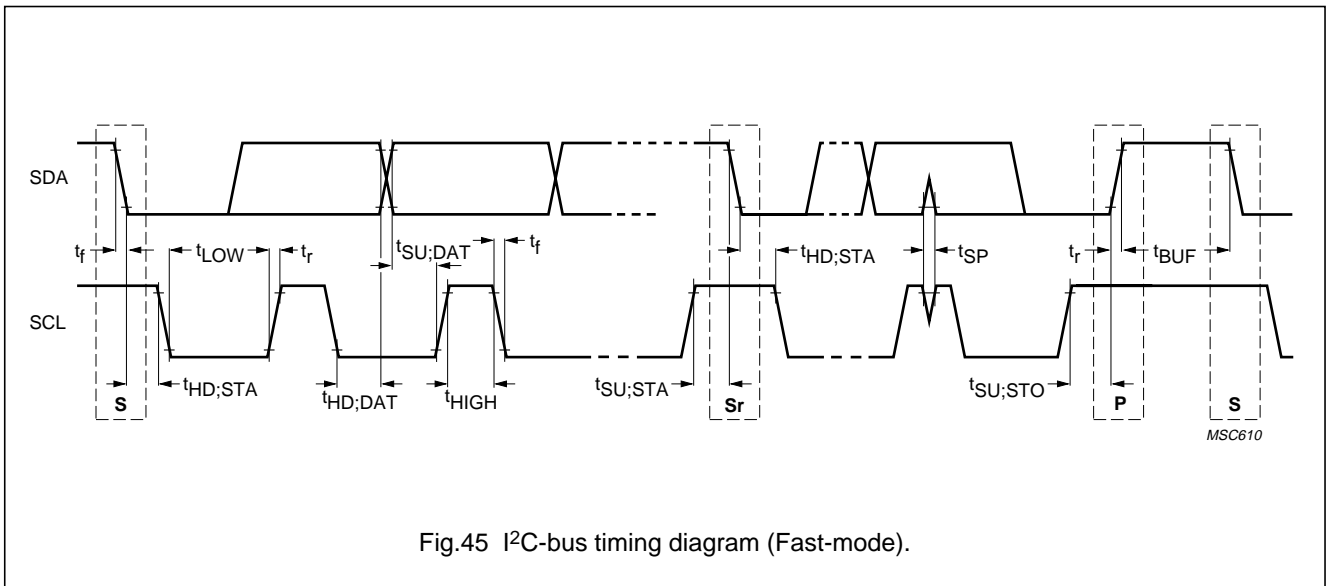

Fig.45 I²C-bus timing diagram (Fast-mode).

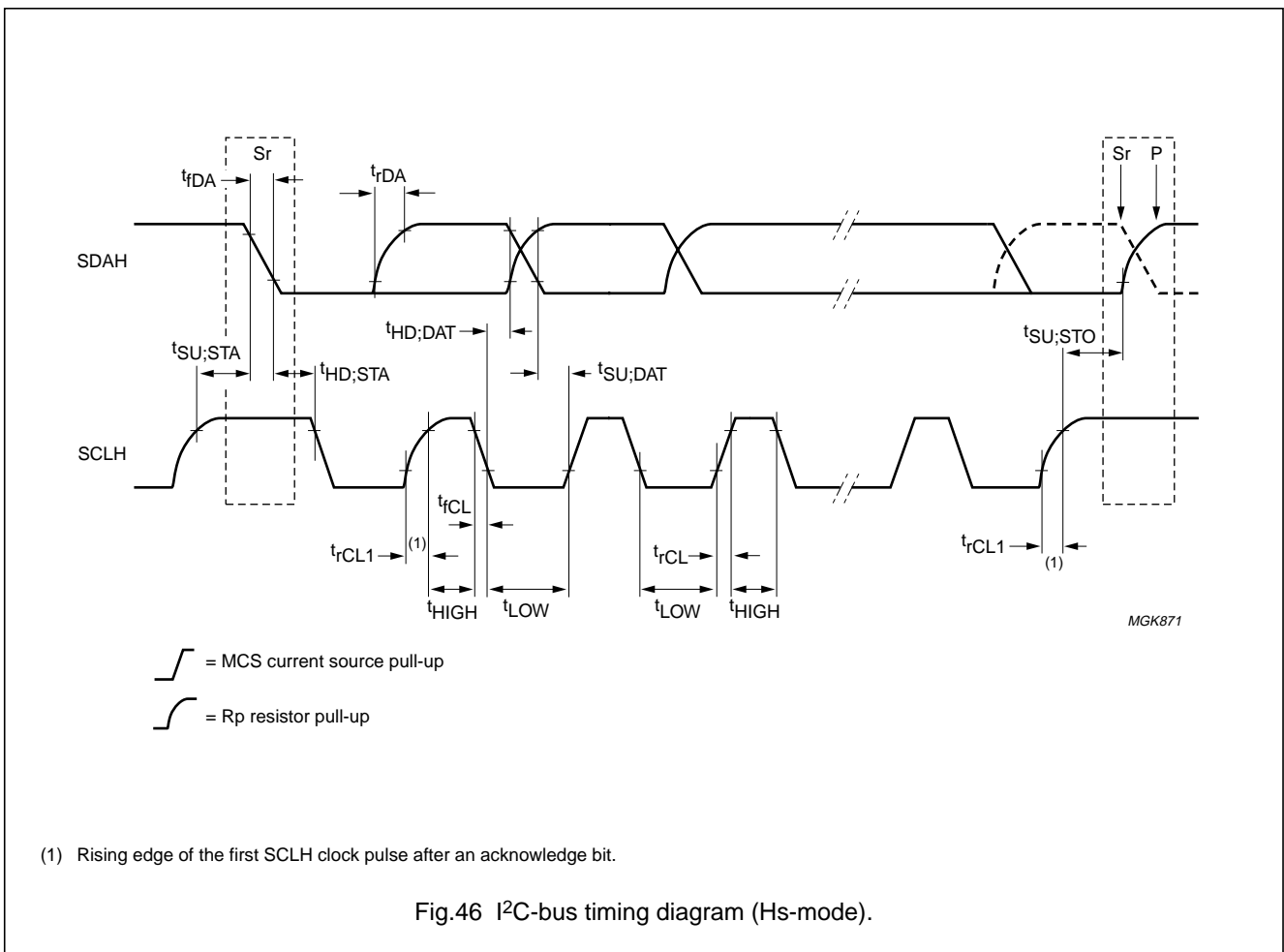

Fig.46 I²C-bus timing diagram (Hs-mode).

(67 + 1) × 102 pixels matrix LCD driver

PCF8813

17 MODULE MAKER PROGRAMMING

One Time Programmable (OTP) technology has been implemented on the PCF8813. This enables the module maker to program some features of the PCF8813 after it has been assembled on an LCD module. Programming is made under the control of the interfaces and using the special pad V_OTPPROG. This pad must be made available on the module glass but does not need to be accessed by the set maker.

Module maker programming is an extension of the normal functions of the PCF8813 and is effective until specifically instructed otherwise with the disable OTP command.

The PCF8813 features three module maker programmable parameters:

- V_{LCD} calibration (5 bits)
- Manufacturer identity (3 bits)
- Seal bit (1-bit).

17.1 LCD voltage calibration

Referring to Fig.47, the V_{LCD} calibration parameter comprises a 5-bit code (V_{CAL}[4:0]). The code is implemented in twos complement notation giving a positive or negative offset to the V_{PR} register. The range of the V_{PR}[6:0] register is 0 to 127. The adder in the circuit takes this into account by having underflow and overflow protection added to it. In the event of an overflow, the output will be clamped to 255, and in the case of an underflow the output will be clamped to 0.

Given that

V_{OP} = V_{CAL} + V_{PR*}

and

V_{LCD} = a + V_{OP} × b |_{T(norm)}

V_{LCD} can be calculated using parameters a and b that are defined in Table 17. An example of the relationship between V_{CAL} code and the V_{LCD} calibration is shown in Table 19, where b is assumed to be 25.6 mV.

Possible values for V_{CAL} are given in Table 19. The default value for V_{CAL} when OTP is disabled is V_{CAL}[4:0] = 00000.

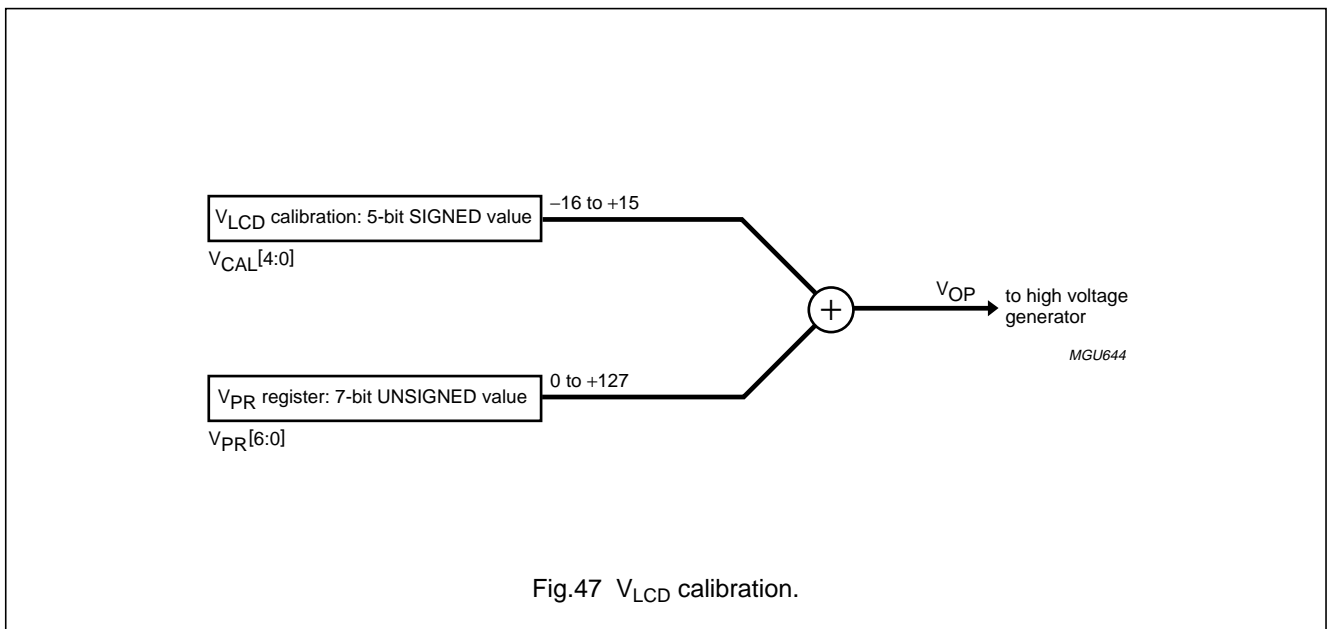

Fig.47 V_{LCD} calibration.

$(67 + 1) \times 102$ pixels matrix LCD driver

PCF8813

Table 19 V_{CAL} codes and associated nominal calibration voltage when the temperature coefficient is set to TC3

V_{CAL}	$V_{CAL}[4:0]$	V_{LCD} CALIBRATION (mV)
+0	00000	0 (default)
+1	00001	+25.6
+2	00010	+51.2
+3	00011	+76.8
+4	00100	+102.4
+5	00101	+128.0
+6	00110	+153.6
+7	00111	+179.2
+8	01000	+204.8
+9	01001	+230.4
+10	01010	+256.0
+11	01011	+281.6
+12	01100	+307.2
+13	01101	+332.8
+14	01110	+358.4
+15	01111	+384.0
-1	11111	-25.6
-2	11110	-51.2
-3	11101	-76.8
-4	11100	-102.4
-5	11011	-128.0
-6	11010	-153.6
-7	11001	-179.2
-8	11000	-204.8
-9	10111	-230.4
-10	10110	-256.0
-11	10101	-281.6
-12	10100	-307.2
-13	10011	-332.8
-14	10010	-358.4
-15	10001	-384.0
-16	10000	-409.6

17.2 Manufacturer identity

The second OTP feature defines the manufacturer identity. A 3-bit code MF[2:0] is used to define this parameter. The default manufacturer identity is MF[2:0] = 000.

17.3 Seal bit

Module maker programming is performed in a special mode; the calibration mode MM. This mode is entered via the interface command, MM. To prevent wrongful programming, a seal bit prevents the device from entering the calibration mode. This seal bit, once programmed, cannot be reversed, thus further changes in programmed values are not possible. However it is possible to disable all programmed values by applying the disable OTP command.

Applying the programming voltages when not in MM mode will have no effect on the programmed values.

Table 20 Seal bit definition

SEAL BIT	ACTION
0	possible to enter calibration mode
1	calibration mode disabled

17.4 One time programming**17.4.1 ARCHITECTURE**

The OTP circuitry in the PCF8813 contains nine bits of data: five for V_{LCD} calibration, three for the manufacturer identity and one for the seal bit. The circuitry for 1-bit is called an OTP slice. Each OTP slice consists of two main parts: the OTP cell (a non-volatile memory cell) and the shift register cell (a flip-flop). The OTP cells are accessible only through their shift register cells; both reading-from and writing-to the OTP cells are performed with the shift register cells, but only the shift register cells are visible to the rest of the circuit. The basic OTP architecture is shown in Fig.48.

(67 + 1) × 102 pixels matrix LCD driver

PCF8813

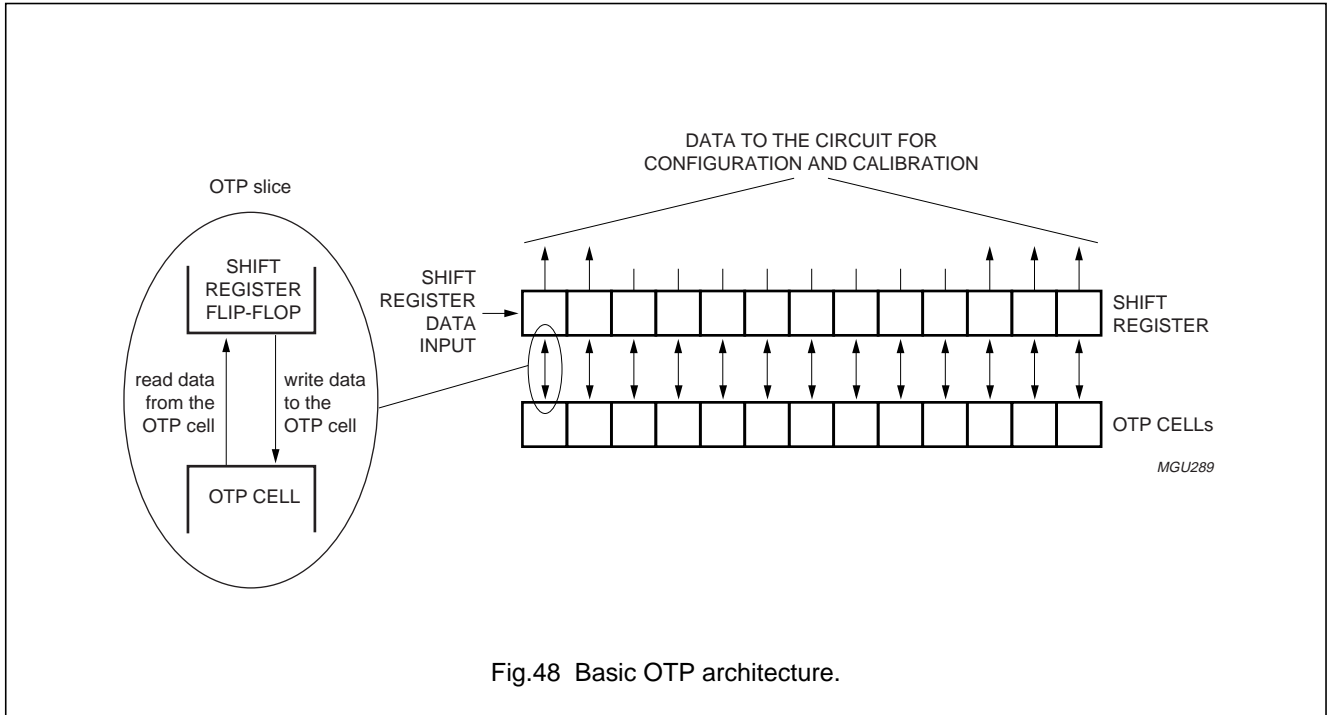

Fig.48 Basic OTP architecture.

17.4.2 OPERATIONS

The OTP architecture allows the following operations:

- The OTP circuit in the PCF8813 is initialized when a reset is initiated. After the reset initiation, OTP circuits can be disabled only by sending the disable OTP command.
- Reading data from the OTP cells. The content of the non-volatile OTP cells is transferred to the shift register where it may affect operation of the PCF8813.
- Writing data to the OTP cells. All 9 bits of data are shifted first into the shift register via the serial interface. Then the content of the shift register is transferred to the OTP cells (there are some limitations related to storing data in these cells; see Section 17.6).
- Checking calibration without writing to the OTP cells. Shifting data into the shift register allows the effects of the V_{LCD} voltage to be observed.

All OTP circuitry of the PCF8813 is enabled until the disable OTP command is given. Once enabled, the reading of data from the OTP cells is initiated by either:

- Exit from Power-down mode
- The Refresh command (power control). This command works only when the driver is not in Power-down.

In both cases, the time required for the reading operation to complete is up to 5 ms.

The shifting of data into the shift register is performed in the special mode MM. In the PCF8813, the MM mode is entered through the MM command. Once in the MM mode, the data is shifted into the shift register via any of the interfaces at the rate of 1-bit per command. After transmitting the last (9th) bit and exiting the MM mode, the interface is again in the normal mode and all other commands can be sent. Care should be taken that 9 bits of data (or a multiple of 9) are always transferred before exiting the MM mode, otherwise the bits will be in the wrong positions.

The value of the seal bit in the shift register is always zero at reset (also applies to all other bits). To make sure the security feature works correctly, the MM command is disabled until a refresh has been made. Once a refresh is completed, the seal bit value in the shift register is valid and permission to enter MM mode can thus be determined.

The 9 bits are shifted into the shift register in a predefined order: first 5 bits of $V_{CAL}[4:0]$, followed by 3 bits for $MF[2:0]$ and then the seal bit. The MSB is always first, that is the first bit shifted is $V_{CAL}[4]$ and the seal bit is the last bit.

(67 + 1) × 102 pixels matrix LCD driver

PCF8813

17.5 Interface commands

Instructions additional to those of the instruction set (Table 5) are given in Table 21.

Table 21 Additional instructions

INSTRUCTION	D/C	R/W	COMMAND BYTE								ACTION
			D7	D6	D5	D4	D3	D2	D1	D0	
Reset											enable OTP circuitry
Function set	0	0	0	0	1	0	0	0	0	0	exit Power-down
REF (refresh)	0	0	0	0	0	1	0	0	0	PC	switch HVgen on/off to force refresh of shift register
											wait 5 ms for refresh to take effect
Function set	0	0	0	0	1	0	0	1	0	1	set PD = 1 and H = 1
MM	0	0	0	0	0	1	1	1	1	0	enter MM mode

17.5.1 DISABLE OTP COMMAND

This is a special instruction for the PCF8813 which disables all included OTP circuitry. In this case, all OTP-related commands are inactive. V_{CAL} and MF have no effect on V_{LCD} and manufacture identification respectively. Once disabled, the mode can only be enabled via a reset.

17.5.2 MODULE MAKER CALIBRATION

Instruction (MM) enters the device into the calibration mode. This mode enables the shift register for loading and allows programming of the non-volatile OTP cells to take place. If the seal bit is set, then this mode cannot be accessed and the instruction will be ignored. Once in calibration mode all commands are interpreted as shift register data. The mode can only be exited by sending data with bit D7 set to logic 0. Reset will also clear this mode. Each shift register data byte is preceded by D/C = 0 and has only three significant bits, thus the remaining five bits are ignored. Bit D7 is the continuation bit (D7 = 1 indicates remain in MM mode; D7 = 0 indicates exit MM mode). D6 has to be logic 0 until the last bit when the seal bit is set, in which case this is set to logic 1 (D6 is set to logic 1 only when the high voltage used for programming the cells is about to be applied). Bit D0 is the data bit and its value is shifted into the OTP shift register on the falling edge of the SCLK clock.

17.5.3 REFRESH

The action of the refresh instruction (REF) is to force the OTP shift register to re-load from the non-volatile OTP cells. This instruction takes up to 5 ms to complete. During this time all other instructions may be sent.

In the PCF8813, the refresh instruction is associated with the power control instruction so that the shift register is refreshed automatically every time the high voltage generator is enabled or disabled. However, if this instruction is sent while in Power-down, the PC bits are updated but the refreshing is ignored.

17.6 Filling the shift register

An example of the sequence of commands and data for filling the shift register is shown in Table 22. This example uses the values V_{CAL} = -4 (11100B), MF = 4 (100B is the Philips identifying code) and the seal bit is 0.

It is assumed that the PCF8813 has just been reset. After transmitting the last bit the PCF8813 can exit or remain in MM mode (see Table 22, step 1). When in MM mode, the interface does not recognize commands in the normal sense.

After this sequence has been applied, it is possible to observe the impact of the data shifted in. The sequence described is not useful for OTP programming because the number of bits with value = 1 is greater than that allowed for programming (see Section 17.7). Figure 49 shows the shift register after this action.

(67 + 1) × 102 pixels matrix LCD driver

PCF8813

Table 22 Example sequence of shift register filling

STEP	D/C	R/W	D7	D6	D5	D4	D3	D2	D1	D0	ACTION
1	reset										reset to enable OTP circuitry
1	0	0	0	0	1	0	0	0	0	0	exit Power-down (PD = 0)
3	0	0	0	0	0	1	0	0	1	PC	switch HV/gen on/off to force refresh of shift register
											wait 5 ms for refresh to take effect
4	0	0	0	0	1	0	0	1	0	1	set PD to 1 ⁽²⁾ and H to 1
5	0	0	0	0	0	1	1	1	1	0	enter MM mode
6	0	0	1	0	X	X	X	X	X	1	shift-in data; V _{CAL} [4] is first bit ⁽³⁾
7	0	0	1	0	X	X	X	X	X	1	V _{CAL} [3]
8	0	0	1	0	X	X	X	X	X	1	V _{CAL} [2]
9	0	0	1	0	X	X	X	X	X	0	V _{CAL} [1]
10	0	0	1	0	X	X	X	X	X	0	V _{CAL} [0]
11	0	0	1	0	X	X	X	X	X	1	MF[2]
12	0	0	1	0	X	X	X	X	X	0	MF[1]
13	0	0	1	0	X	X	X	X	X	0	MF[0]
14	0	0	1	0	X	X	X	X	X	0	seal bit; remain in MM mode

Notes

1. X = don't care.
2. PD does not have to be set to 1 if the effects of V_{CAL} are intended to be observed on V_{LCDOUT}.
3. Bit data is not in the correct shift register position until all bits have been sent.

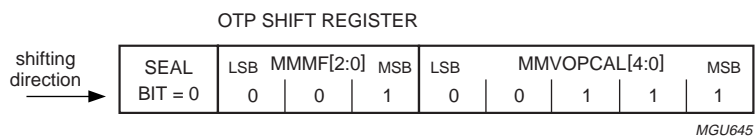

Fig.49 Shift register contents after example sequence of Table 22.

$(67 + 1) \times 102$ pixels matrix LCD driver

PCF8813

17.7 Programming flow

Programming is achieved in MM mode and with application of the programming voltages. Since the data for programming the OTP cell is contained in the corresponding shift register cell, the shift register cell must be loaded with a 1 in order to program the corresponding OTP cell. If the shift register cell contains a 0, then no action will take place when the programming voltages are applied.

Once programmed, an OTP cell cannot be de-programmed. Also, a previously programmed cell that is an OTP cell containing a 1 must not be re-programmed.

During programming a substantial current flows in the V_{LCDIN} pad. For this reason programming only one OTP

cell at a time is recommended. This is achieved by filling all but one shift register cells with 0.

The programming specification refers to the voltages at the chip pads, therefore contact resistance must be considered by the user.

An example of the sequence of commands and data for OTP programming is given in Table 23. The order for programming cells is not significant but it is recommended that the seal bit is programmed last. Once the seal bit has been programmed it is not possible to re-enter the MM mode.

It is assumed that the PCF8813 has been reset just before the programming commences.

Table 23 Example sequence for OTP programming

STEP	D/C	R/W	D7	D6	D5	D4	D3	D2	D1	D0	ACTION
1			reset								enable OTP by applying a reset
1	0	0	0	0	1	0	0	0	0	0	exit Power-down (PD = 0)
3	0	0	0	0	0	1	0	0	1	PC	switch HVgen on/off to force refresh of shift register
											wait 5 ms for refresh to take effect
4	0	0	0	0	1	0	0	1	0	1	re-enter Power-down (PD = 1 and H = 1)
5	0	0	0	0	0	1	1	1	1	0	enter MM mode
6	0	0	1	0	X	X	X	X	X	1	$V_{CAL}[4]$ (the only bit with value of 1)
7	0	0	1	0	X	X	X	X	X	1	$V_{CAL}[3]$
8	0	0	1	0	X	X	X	X	X	1	$V_{CAL}[2]$
9	0	0	1	0	X	X	X	X	X	0	$V_{CAL}[1]$
10	0	0	1	0	X	X	X	X	X	0	$V_{CAL}[0]$
11	0	0	1	0	X	X	X	X	X	0	MF[2]
12	0	0	1	0	X	X	X	X	X	0	MF[1]
13	0	0	1	0	X	X	X	X	X	0	MF[0]
14	0	0	1	1	X	X	X	X	X	0	seal bit; remain in CALMM mode
15	–	–	–	–	–	–	–	–	–	–	apply programming voltage at pads $V_{OTPPROG}$ and V_{LCDIN}
Repeat steps 6 to 15 for each bit that should be programmed to 1											
15	–	–	–	–	–	–	–	–	–	–	apply external reset

Note

1. X = don't care.

$(67 + 1) \times 102$ pixels matrix LCD driver

PCF8813

17.8 Programming specification

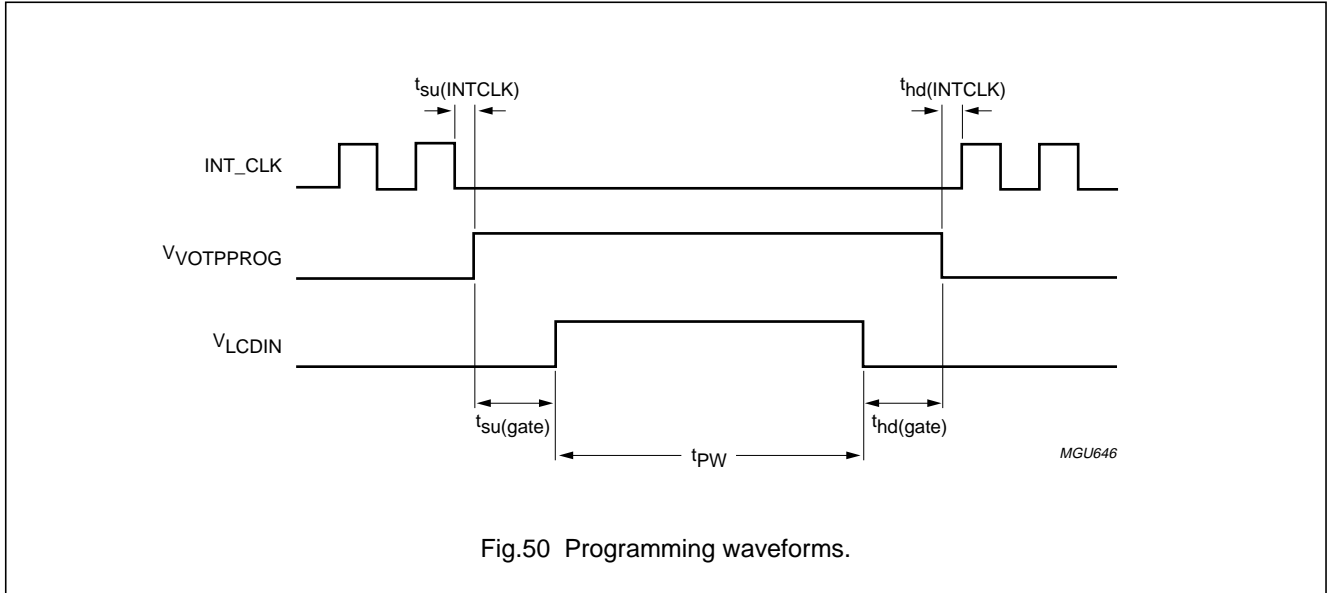

Fig.50 Programming waveforms.

Table 24 Programming parameters

SYMBOL	PARAMETER	CONDITION	MIN.	TYP.	MAX.	UNIT
V _{DD1}	logic supply voltage		2.4	–	3.3	V
V _{OTPPROG}	voltage applied to pad V _{OTPPROG}	V _{OTPPROG} relative to V _{SS1} ; note 1 programming active programming inactive	11.0 0	11.5 –	12.0 V _{DD1}	V V
V _{LCDIN}	voltage applied to pad V _{LCDIN}	V _{LCDIN} relative to V _{SS1} ; notes 1, 2 programming active programming inactive	9.0 0	9.50 –	10.5 V _{DD2}	V V
I _{OTPPROG}	current drawn during programming		–	100	200	μA
I _{LCDIN}	current drawn during programming	when programming one bit to logic 1	–	850	1000	μA
T _{prog}	ambient temperature during programming		0	25	40	°C
t _{su} (INTCLK)	internal data set-up time after last clock		1	–	–	μs
t _{hd} (INTCLK)	internal data hold time before next clock		1	–	–	μs
t _{su} (gate)	V _{OTPPROG} set-up time prior to programming		1	–	10	ms
t _{hd} (gate)	V _{OTPPROG} hold time after programming		1	–	10	ms
t _{pW}	programming voltage pulse width		100	120	200	ms

Notes

1. The voltage drop across the ITO track and zebra connector must be taken into account to guarantee sufficient voltage at the chip pads.
2. The high voltage generator must be disabled (V_{PR} = 0 and PRS = 0) when pad V_{LCDIN} is being driven.

(67 + 1) × 102 pixels matrix LCD driver

PCF8813

17.9 Programming examples

Table 25 Programming example for PCF8813 with serial interface (3-line serial, 3-line SPI or 4-line SPI)

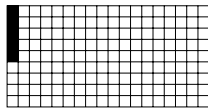
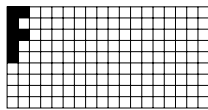
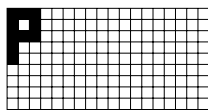
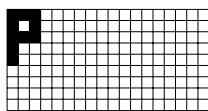
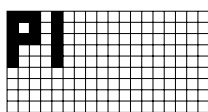
STEP	SERIAL BUS BYTE									DISPLAY	OPERATION
	D/C	DB7	DB6	DB5	DB4	DB3	DB2	DB1	DB0		
1	start										SC \bar{E} is going low
2	0	0	0	1	0	0	0	0	1		function set: PD = 0, V = 0; select extended instruction set (H = 1)
3	0	0	0	0	1	0	0	0	1		set PRS to higher programming range (PRS = 1)
4	0	1	0	0	1	0	0	0	0		set V _{PR} : V _{PR} * = (a + 132* × b) = 8.596 V (required voltage is dependent on liquid crystal operating environment)
5	0	0	0	1	0	0	0	0	0		function set: PD = 0, V = 0; select normal instruction set (H = 0)
6	0	0	0	0	0	1	1	0	0		display control: set normal mode (D = 1 and E = 0)
7	0	0	0	0	1	0	1	1	0		set data order: DO = 0
	0	0	0	0	0	0	0	0	0		
8	–	1	1	1	0	0	0	0	0		option available in 3-line SPI for setting display data length command (7 shown)
	–	0	0	0	0	0	0	1	1		
9	1	0	0	0	1	1	1	1	1		data write: Y and X are initialized to 0 by default, so they are not set here
10	1	0	0	0	0	0	1	0	1		data write
11	1	0	0	0	0	0	1	1	1		data write
12	1	0	0	0	0	0	0	0	0		data write
13	1	0	0	0	1	1	1	1	1		data write

(67 + 1) × 102 pixels matrix LCD driver

PCF8813





STEP	SERIAL BUS BYTE									DISPLAY	OPERATION
	D/C	DB7	DB6	DB5	DB4	DB3	DB2	DB1	DB0		
14	1	0	0	0	0	0	1	0	0	 <small>MGS410</small>	data write
15	1	0	0	0	1	1	1	1	1	 <small>MGS411</small>	data write
16	0	0	0	0	0	1	1	0	1	 <small>MGS412</small>	display control: set inverse video mode (D = 1 and E = 1)
17	0	1	0	0	0	0	0	0	0	 <small>MGS412</small>	set X address of RAM: set address to '0000000'
18	1	0	0	0	0	0	0	0	0	 <small>MGS414</small>	data write

Table 26 Programming example for PCF8813 with I²C -bus

STEP	SERIAL BUS BYTE									DISPLAY	OPERATION
	D/C	DB7	DB6	DB5	DB4	DB3	DB2	DB1	DB0		
1	I ² C-bus start										
2	–	0	1	1	1	1	SA1	SA0	0		slave address for write
3	–	0	0	0	0	0	0	0	0		control byte with cleared CO bit and D/C set to logic 0
4	–	0	0	1	0	0	0	0	1		function set: PD = 0, V = 0; select extended instruction set (H = 1)
5	–	0	0	0	1	0	0	0	1		set PRS to higher programming range (PRS = 1)
6	–	1	0	0	1	0	0	0	0		set V _{PR} : V _{PR} * = (a + 132* × b) = 8.596 V (required voltage is dependent on liquid crystal operating environment)
7	–	0	0	1	0	0	0	0	0		function set: PD = 0; V = 0; select normal instruction set (H = 0)

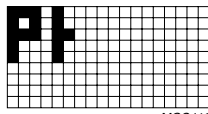
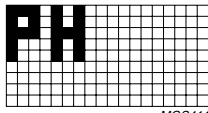

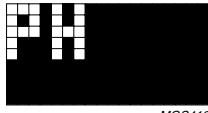
(67 + 1) × 102 pixels matrix LCD driver

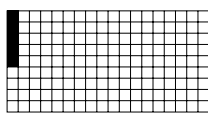
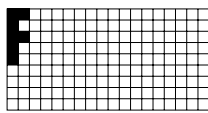
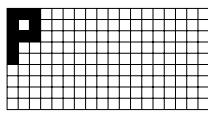
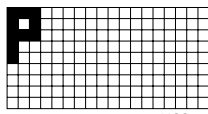
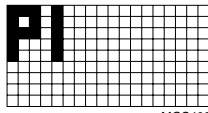
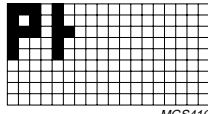
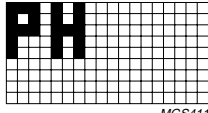
PCF8813

STEP	SERIAL BUS BYTE									DISPLAY	OPERATION	
	D/C	DB7	DB6	DB5	DB4	DB3	DB2	DB1	DB0			
8	–	0	0	0	0	1	1	0	0		display control: set normal mode (D = 1 and E = 0)	
9	–	0	0	0	1	0	1	1	0		display configuration (DO = 0)	
	–	0	0	0	0	0	1	0	0			
10	–	I ² C-bus start										restart: to write into the display RAM the D/C must be set to logic 1, therefore a control byte is needed
11	–	0	1	1	1	1	SA1	SA0	0		slave address for write	
12	–	0	1	0	0	0	0	0	0		control byte with cleared CO bit and D/C set to logic 1	
13	1	0	0	0	1	1	1	1	–	 <small>MGS405</small>	data write: Y and X are initialized to 0 by default, so they are not set here	
14	1	0	0	0	0	0	0	1	–	 <small>MGS406</small>	data write	
15	1	0	0	0	0	0	1	1	–	 <small>MGS407</small>	data write	
16	1	0	0	0	0	0	0	0	–	 <small>MGS407</small>	data write	
17	1	0	0	0	1	1	1	1	–	 <small>MGS409</small>	data write	
18	1	0	0	0	0	0	1	0	–	 <small>MGS410</small>	data write	
19	1	0	0	0	1	1	1	1	–	 <small>MGS411</small>	data write	
20	I ² C-bus start										restart	
21	–	0	1	1	1	1	SA1	SA0	0		slave address for write	
22	–	1									control byte with set CO bit and D/C set to logic 0	

$(67 + 1) \times 102$ pixels matrix LCD driver

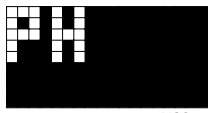
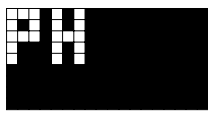
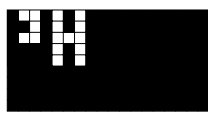
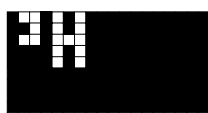
PCF8813

STEP	SERIAL BUS BYTE									DISPLAY	OPERATION
	D/C	DB7	DB6	DB5	DB4	DB3	DB2	DB1	DB0		
23	–	0	0	0	0	1	1	0	1		display control: set inverse video mode (D = 1 and E = 1)
24	–	1	0	0	0	0	0	0	0		control byte with set CO bit and D/C set to logic 0
25	–	1	0	0	0	0	0	0	0		Set X address of RAM: set address to 0000000
26	–	1	1	0	0	0	0	0	0		control byte with set CO bit and D/C set to logic 1
27	–	0	0	0	0	0	0	0	0		data write
28	–	1	0	0	0	0	0	0	0		control byte with set CO bit and D/C set to logic 0
29	–	1	0	0	0	0	0	0	0		set X address of RAM: set address to 0000000
30	I ² C-bus start										restart
31	–	0	1	1	1	1	SA1	SA0	0		slave address for write
32	–	1	1	0	0	0	0	0	0		control byte with set CO bit and D/C set to logic 1
33	–	1	1	1	1	1	0	0	0		write data
34	–	1	0	0	0	0	0	0	0		control byte with set CO bit and D/C set to logic 0

(67 + 1) × 102 pixels matrix LCD driver

PCF8813

18 APPLICATION INFORMATION

For additional application information, refer to application note "AN10170".

18.1 Protection from light

Semiconductors are light-sensitive. Exposure to light sources can cause malfunctions, therefore the IC should be protected from light in the application. Light protection needs to be applied to all sides of the IC (front, rear and all edges).

18.2 Application examples

In the following application examples, the required minimum values of the external capacitors are:

- C_{VLCD} = 100 nF minimum
- C_{VDD}, C_{VDD1} and C_{VDD2} = 1 μF minimum
- Higher capacitor values are recommended for ripple reduction.

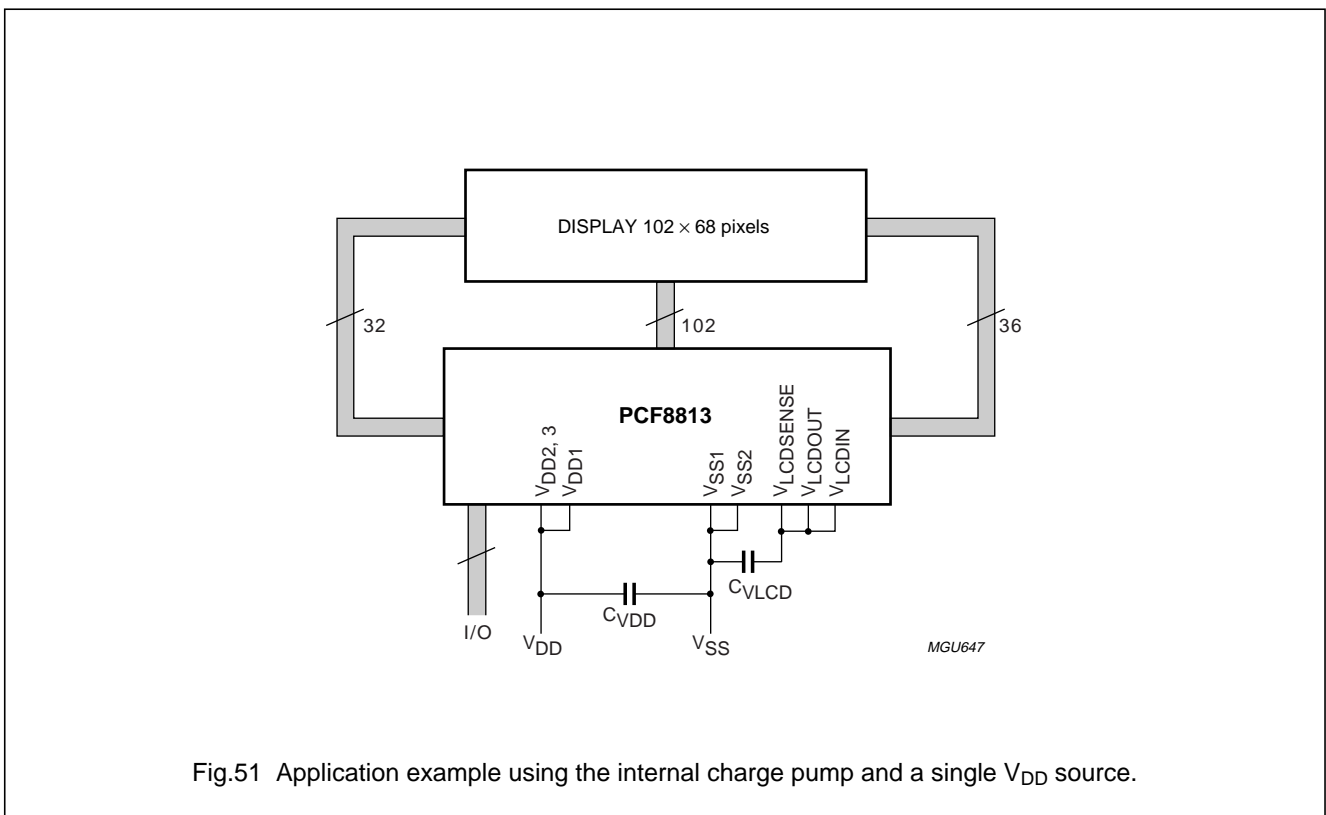
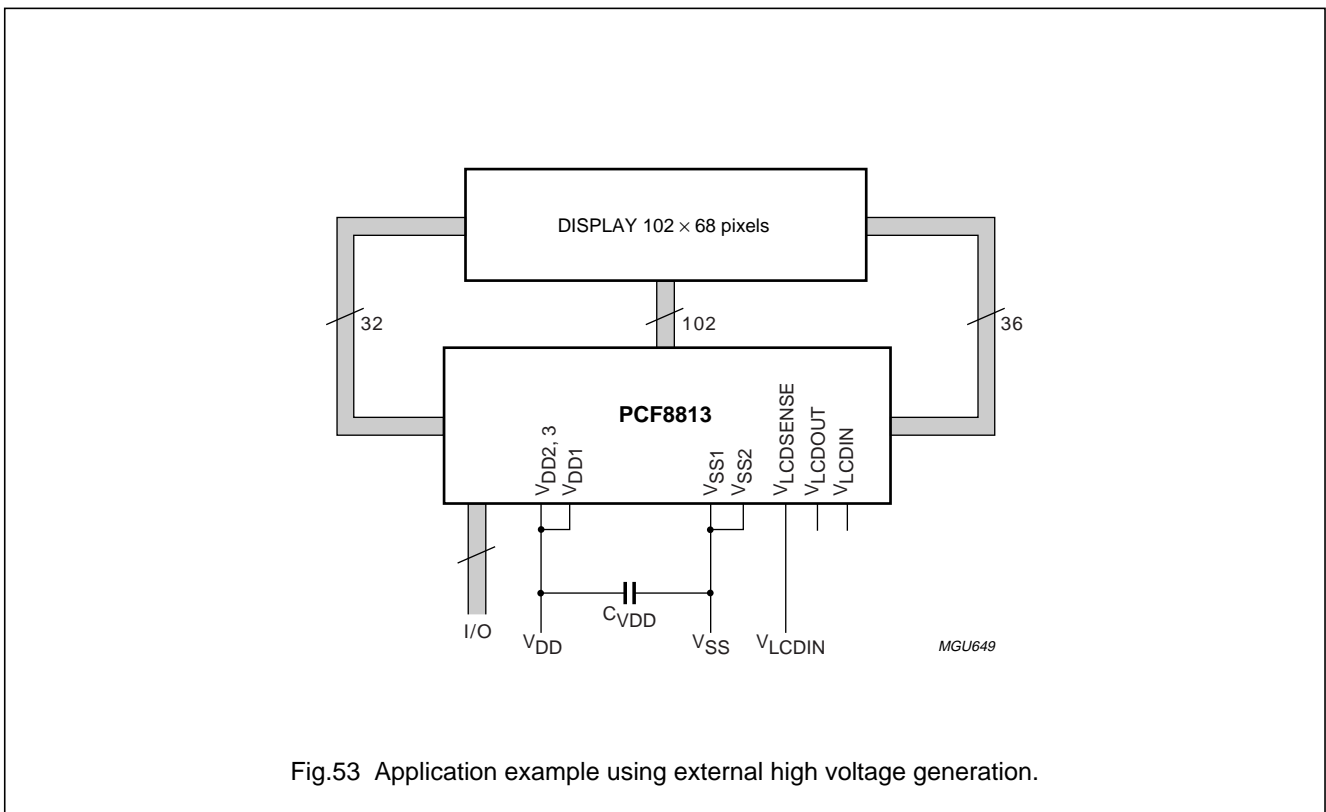
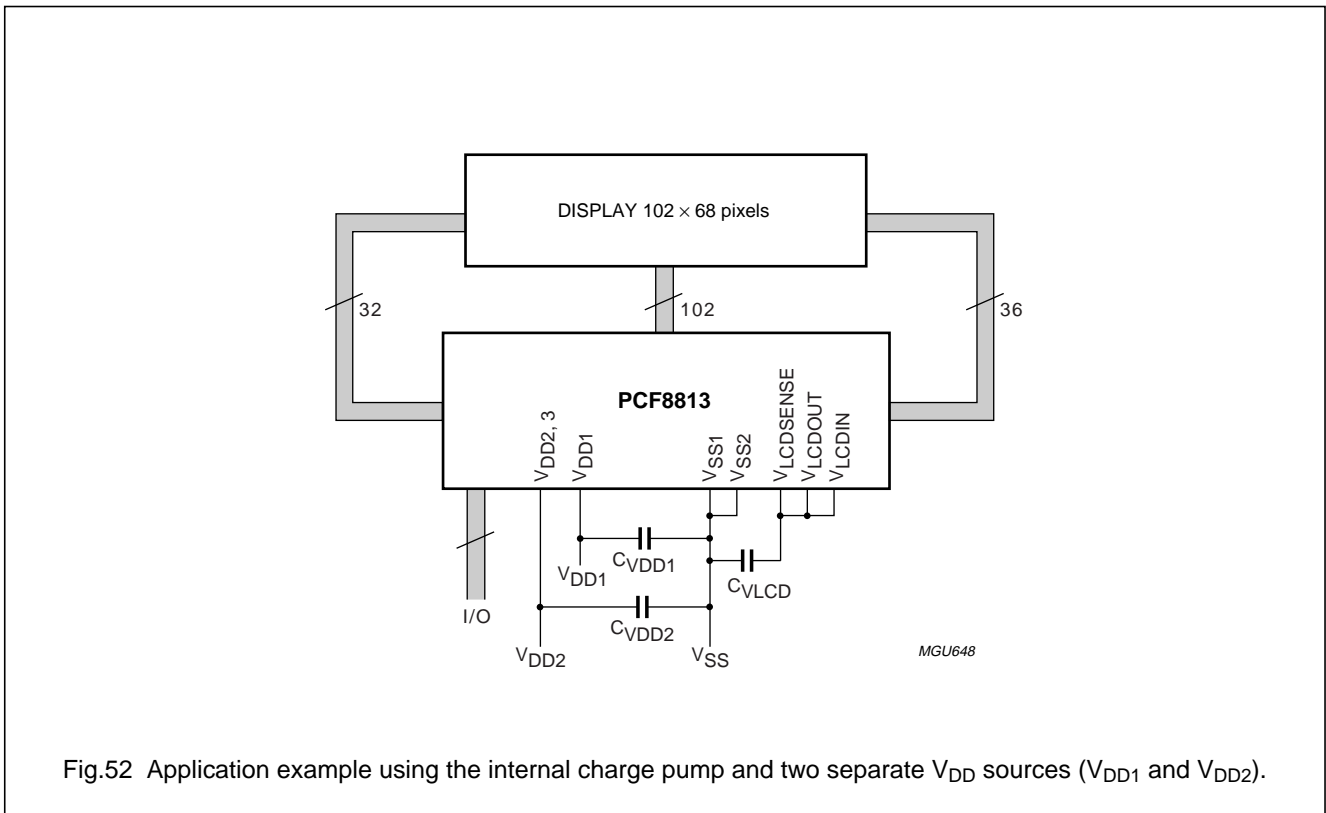

Fig.51 Application example using the internal charge pump and a single V_{DD} source.

(67 + 1) × 102 pixels matrix LCD driver

PCF8813



$(67 + 1) \times 102$ pixels matrix LCD driver

PCF8813

20 BONDING PAD INFORMATION

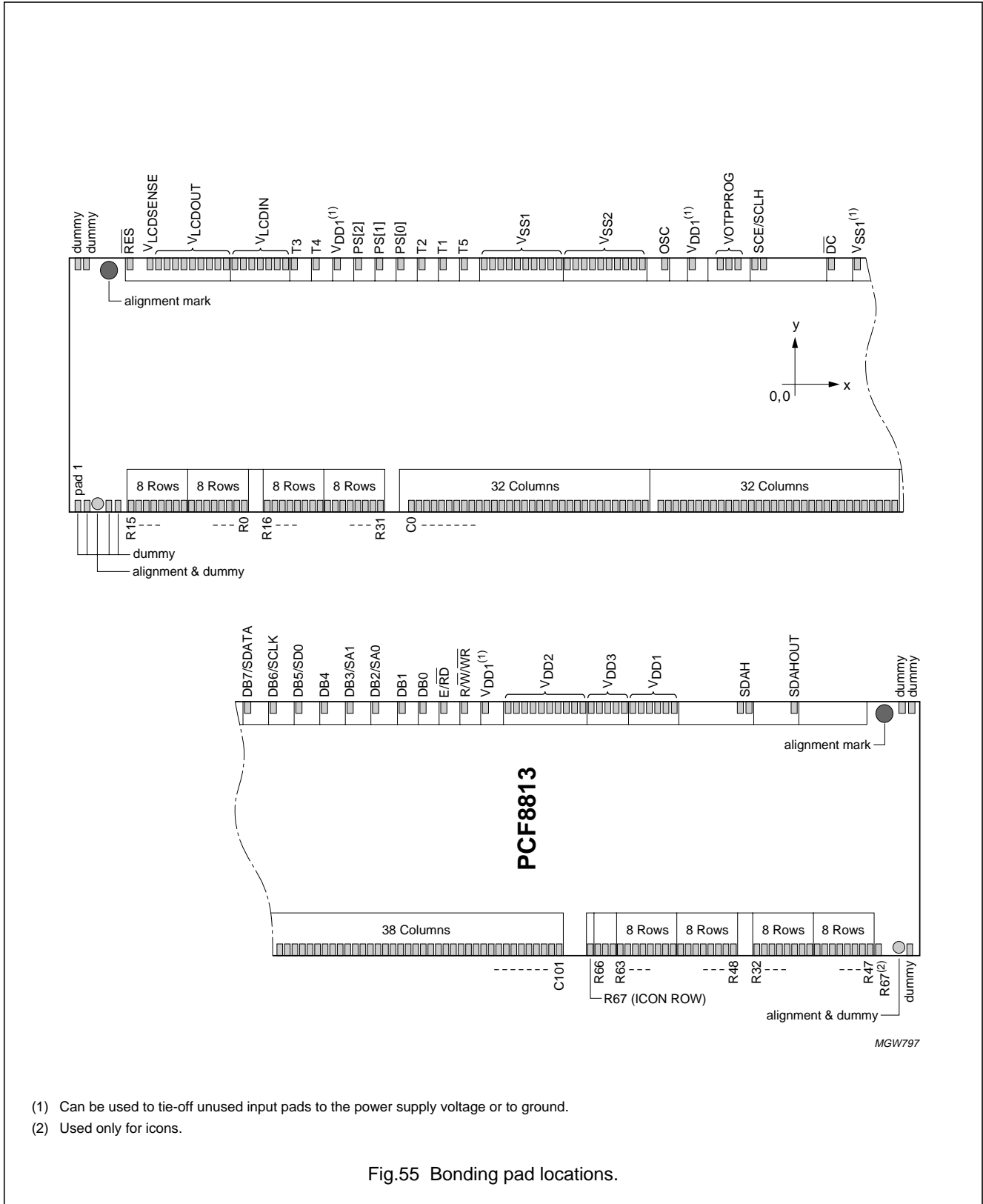

- (1) Can be used to tie-off unused input pads to the power supply voltage or to ground.
- (2) Used only for icons.

Fig.55 Bonding pad locations.

$(67 + 1) \times 102$ pixels matrix LCD driver

PCF8813

Table 27 Bonding pad locations

All x and y coordinates are referenced to the centre of the chip; dummy bumps should never be connected to any electrical nodes; dimensions in μm ; see Fig.55.

SYMBOL	PAD	COORDINATES	
		x	y
dummy	1	-5328	+814.5
dummy	2	-5328	-814.5
dummy	3	-5274	-814.5
dummy and alignment	4	-5175	-814.5
dummy	5	-5085	-814.5
dummy	6	-5031	-814.5
R15	7	-4869	-814.5
R14	8	-4815	-814.5
R13	9	-4761	-814.5
R12	10	-4707	-814.5
R11	11	-4653	-814.5
R10	12	-4599	-814.5
R9	13	-4545	-814.5
R8	14	-4491	-814.5
R7	15	-4437	-814.5
R6	16	-4383	-814.5
R5	17	-4329	-814.5
R4	18	-4275	-814.5
R3	19	-4221	-814.5
R2	20	-4167	-814.5
R1	21	-4113	-814.5
R0	22	-4059	-814.5
R16	23	-3843	-814.5
R17	24	-3789	-814.5
R18	25	-3735	-814.5
R19	26	-3681	-814.5
R20	27	-3627	-814.5
R21	28	-3573	-814.5
R22	29	-3519	-814.5
R23	30	-3465	-814.5
R24	31	-3411	-814.5
R25	32	-3357	-814.5
R26	33	-3303	-814.5
R27	34	-3249	-814.5
R28	35	-3195	-814.5

SYMBOL	PAD	COORDINATES	
		x	y
R29	36	-3141	-814.5
R30	37	-3087	-814.5
R31	38	-3033	-814.5
C0	39	-2871	-814.5
C1	40	-2817	-814.5
C2	41	-2763	-814.5
C3	42	-2709	-814.5
C4	43	-2655	-814.5
C5	44	-2601	-814.5
C6	45	-2547	-814.5
C7	46	-2493	-814.5
C8	47	-2439	-814.5
C9	48	-2385	-814.5
C10	49	-2331	-814.5
C11	50	-2277	-814.5
C12	51	-2223	-814.5
C13	52	-2169	-814.5
C14	53	-2115	-814.5
C15	54	-2061	-814.5
C16	55	-2007	-814.5
C17	56	-1953	-814.5
C18	57	-1899	-814.5
C19	58	-1845	-814.5
C20	59	-1791	-814.5
C21	60	-1737	-814.5
C22	61	-1683	-814.5
C23	62	-1629	-814.5
C24	63	-1575	-814.5
C25	64	-1521	-814.5
C26	65	-1467	-814.5
C27	66	-1413	-814.5
C28	67	-1359	-814.5
C29	68	-1305	-814.5
C30	69	-1251	-814.5
C31	70	-1197	-814.5
C32	71	-1035	-814.5
C33	72	-981	-814.5
C34	73	-927	-814.5
C35	74	-873	-814.5

$(67 + 1) \times 102$ pixels matrix LCD driver

PCF8813

SYMBOL	PAD	COORDINATES	
		x	y
C36	75	-819	-814.5
C37	76	-765	-814.5
C38	77	-711	-814.5
C39	78	-657	-814.5
C40	79	-603	-814.5
C41	80	-549	-814.5
C42	81	-495	-814.5
C43	82	-441	-814.5
C44	83	-387	-814.5
C45	84	-333	-814.5
C46	85	-279	-814.5
C47	86	-225	-814.5
C48	87	-171	-814.5
C49	88	-117	-814.5
C50	89	-63	-814.5
C51	90	-9	-814.5
C52	91	+45	-814.5
C53	92	+99	-814.5
C54	93	+153	-814.5
C55	94	+207	-814.5
C56	95	+261	-814.5
C57	96	+315	-814.5
C58	97	+369	-814.5
C59	98	+423	-814.5
C60	99	+477	-814.5
C61	100	+531	-814.5
C62	101	+585	-814.5
C63	102	+639	-814.5
C64	103	+801	-814.5
C65	104	+855	-814.5
C66	105	+909	-814.5
C67	106	+963	-814.5
C68	107	+1017	-814.5
C69	108	+1071	-814.5
C70	109	+1125	-814.5
C71	110	+1179	-814.5
C72	111	+1233	-814.5
C73	112	+1287	-814.5
C74	113	+1341	-814.5

SYMBOL	PAD	COORDINATES	
		x	y
C75	114	+1395	-814.5
C76	115	+1449	-814.5
C77	116	+1503	-814.5
C78	117	+1557	-814.5
C79	118	+1611	-814.5
C80	119	+1665	-814.5
C81	120	+1719	-814.5
C82	121	+1773	-814.5
C83	122	+1827	-814.5
C84	123	+1881	-814.5
C85	124	+1935	-814.5
C86	125	+1989	-814.5
C87	126	+2043	-814.5
C88	127	+2097	-814.5
C89	128	+2151	-814.5
C90	129	+2205	-814.5
C91	130	+2259	-814.5
C92	131	+2313	-814.5
C93	132	+2367	-814.5
C94	133	+2421	-814.5
C95	134	+2475	-814.5
C96	135	+2529	-814.5
C97	136	+2583	-814.5
C98	137	+2637	-814.5
C99	138	+2691	-814.5
C100	139	+2745	-814.5
C101	140	+2799	-814.5
R67	141	+2961	-814.5
R66	142	+3015	-814.5
R65	143	+3069	-814.5
R64	144	+3123	-814.5
R63	145	+3177	-814.5
R62	146	+3231	-814.5
R61	147	+3285	-814.5
R60	148	+3339	-814.5
R59	149	+3393	-814.5
R58	150	+3447	-814.5
R57	151	+3501	-814.5
R56	152	+3555	-814.5

$(67 + 1) \times 102$ pixels matrix LCD driver

PCF8813

SYMBOL	PAD	COORDINATES	
		x	y
R55	153	+3609	-814.5
R54	154	+3663	-814.5
R53	155	+3717	-814.5
R52	156	+3771	-814.5
R51	157	+3825	-814.5
R50	158	+3879	-814.5
R49	159	+3933	-814.5
R48	160	+3987	-814.5
R32	161	+4203	-814.5
R33	162	+4257	-814.5
R34	163	+4311	-814.5
R35	164	+4365	-814.5
R36	165	+4419	-814.5
R37	166	+4473	-814.5
R38	167	+4527	-814.5
R39	168	+4581	-814.5
R40	169	+4635	-814.5
R41	170	+4689	-814.5
R42	171	+4743	-814.5
R43	172	+4797	-814.5
R44	173	+4851	-814.5
R45	174	+4905	-814.5
R46	175	+4959	-814.5
R47	176	+5013	-814.5
R67	177	+5067	-814.5
dummy and alignment	178	+5229	-814.5
dummy	179	+5328	-814.5
dummy	180	+5328	+814.5
dummy	181	+5274	+814.5
dummy	182	+4752	+814.5
SDAHOUT	183	+4500	+814.5
SDAH	184	+4122	+814.5
SDAH	185	+4068	+814.5
V _{DD1}	186	+3528	+814.5
V _{DD1}	187	+3474	+814.5
V _{DD1}	188	+3420	+814.5
V _{DD1}	189	+3366	+814.5
V _{DD1}	190	+3312	+814.5
V _{DD1}	191	+3258	+814.5

SYMBOL	PAD	COORDINATES	
		x	y
V _{DD3}	192	+3204	+814.5
V _{DD3}	193	+3150	+814.5
V _{DD3}	194	+3096	+814.5
V _{DD3}	195	+3042	+814.5
V _{DD3}	196	+2988	+814.5
V _{DD2}	197	+2934	+814.5
V _{DD2}	198	+2880	+814.5
V _{DD2}	199	+2826	+814.5
V _{DD2}	200	+2772	+814.5
V _{DD2}	201	+2718	+814.5
V _{DD2}	202	+2664	+814.5
V _{DD2}	203	+2610	+814.5
V _{DD2}	204	+2556	+814.5
V _{DD2}	205	+2502	+814.5
V _{DD2}	206	+2448	+814.5
V _{DD1}	207	+2286	+814.5
R/W/WR	208	+2124	+814.5
E/RD	209	+1962	+814.5
DB0	210	+1746	+814.5
DB1	211	+1530	+814.5
DB2/SA0	212	+1314	+814.5
DB3/SA1	213	+1098	+814.5
DB4	214	+882	+814.5
DB5/SDOUT	215	+666	+814.5
DB6/ SCLK	216	+450	+814.5
DB7/SDATA	217	+234	+814.5
V _{SS1}	218	+72	+814.5
D/C	219	-90	+814.5
SCE/SCLH	220	-630	+814.5
SCE/SCLH	221	-684	+814.5
V _{OTPPROG}	222	-792	+814.5
V _{OTPPROG}	223	-846	+814.5
V _{OTPPROG}	224	-900	+814.5
V _{DD1}	225	-1008	+814.5
OSC	226	-1296	+814.5
V _{SS2}	227	-1458	+814.5
V _{SS2}	228	-1512	+814.5
V _{SS2}	229	-1566	+814.5
V _{SS2}	230	-1620	+814.5

$(67 + 1) \times 102$ pixels matrix LCD driver

PCF8813

SYMBOL	PAD	COORDINATES	
		x	y
V _{SS2}	231	-1674	+814.5
V _{SS2}	232	-1728	+814.5
V _{SS2}	233	-1782	+814.5
V _{SS2}	234	-1836	+814.5
V _{SS2}	235	-1890	+814.5
V _{SS2}	236	-1944	+814.5
V _{SS1}	237	-1998	+814.5
V _{SS1}	238	-2052	+814.5
V _{SS1}	239	-2106	+814.5
V _{SS1}	240	-2160	+814.5
V _{SS1}	241	-2214	+814.5
V _{SS1}	242	-2268	+814.5
V _{SS1}	243	-2322	+814.5
V _{SS1}	244	-2376	+814.5
V _{SS1}	245	-2430	+814.5
V _{SS1}	246	-2484	+814.5
T5	247	-2646	+814.5
T1	248	-2808	+814.5
T2	249	-2970	+814.5
PS0	250	-3132	+814.5
PS1	251	-3294	+814.5
PS2	252	-3456	+814.5

SYMBOL	PAD	COORDINATES	
		x	y
V _{DD1}	253	-3618	+814.5
T4	254	-3780	+814.5
T3	255	-3942	+814.5
V _{LCDIN}	256	-3996	+814.5
V _{LCDIN}	257	-4050	+814.5
V _{LCDIN}	258	-4104	+814.5
V _{LCDIN}	259	-4158	+814.5
V _{LCDIN}	260	-4212	+814.5
V _{LCDIN}	261	-4266	+814.5
V _{LCDIN}	262	-4320	+814.5
V _{LCDOUT}	263	-4374	+814.5
V _{LCDOUT}	264	-4428	+814.5
V _{LCDOUT}	265	-4482	+814.5
V _{LCDOUT}	266	-4536	+814.5
V _{LCDOUT}	267	-4590	+814.5
V _{LCDOUT}	268	-4644	+814.5
V _{LCDOUT}	269	-4698	+814.5
V _{LCDOUT}	270	-4752	+814.5
V _{LCDOUT}	271	-4806	+814.5
V _{LCDSENSE}	272	-4860	+814.5
RES	273	-5076	+814.5
dummy	274	-5274	+814.5

$(67 + 1) \times 102$ pixels matrix LCD driver

PCF8813

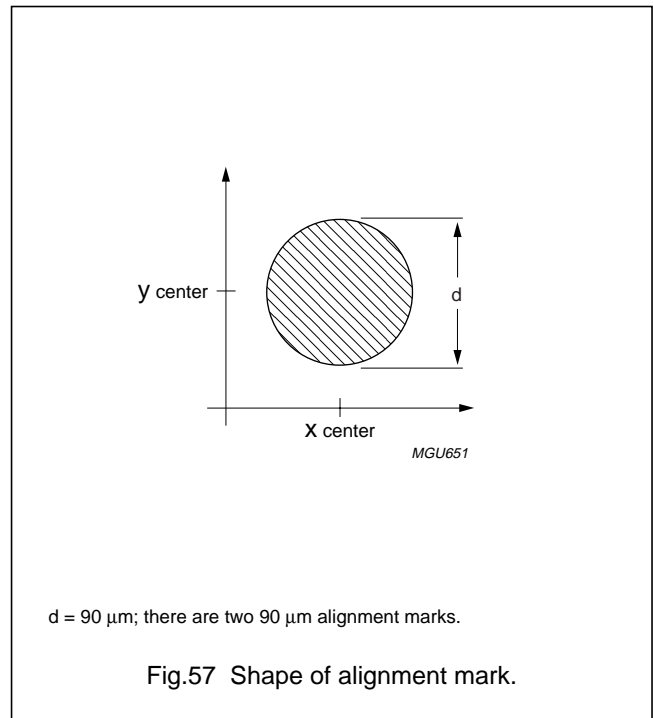
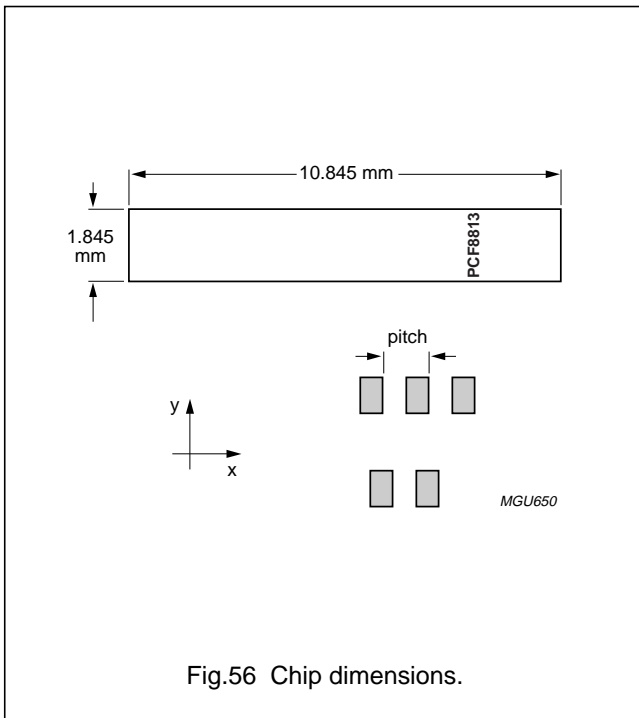

Table 28 Bump size

PARAMETER	VALUE (μm)
Bump width	32
Bump length	81
Bump height	17.5
Minimum pad pitch	54
Pad size, aluminium	45×81
Maximum wafer thickness, including bumps	430
Typical wafer thickness, without bumps	381

(67 + 1) × 102 pixels matrix LCD driver

PCF8813

21 TRAY INFORMATION

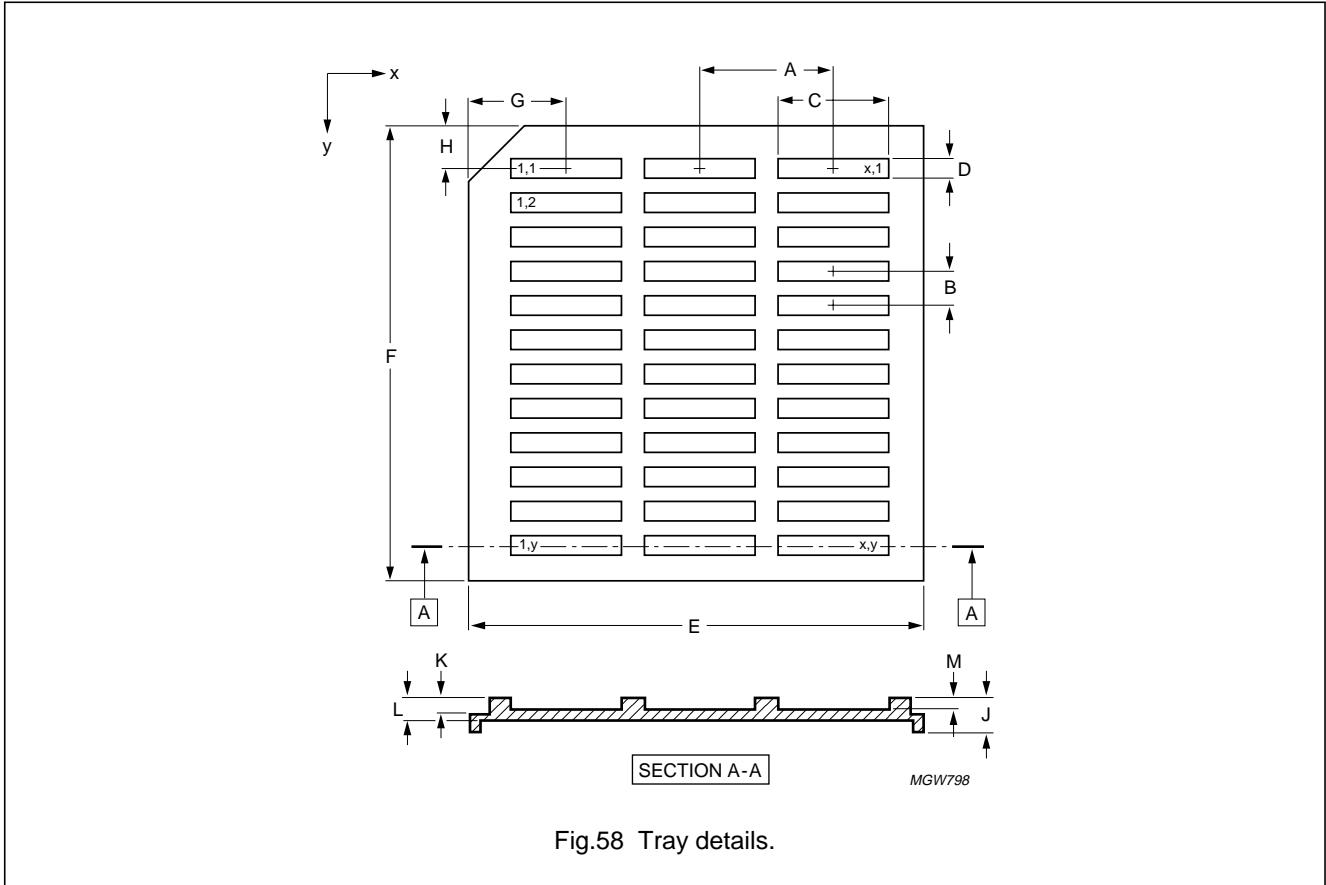
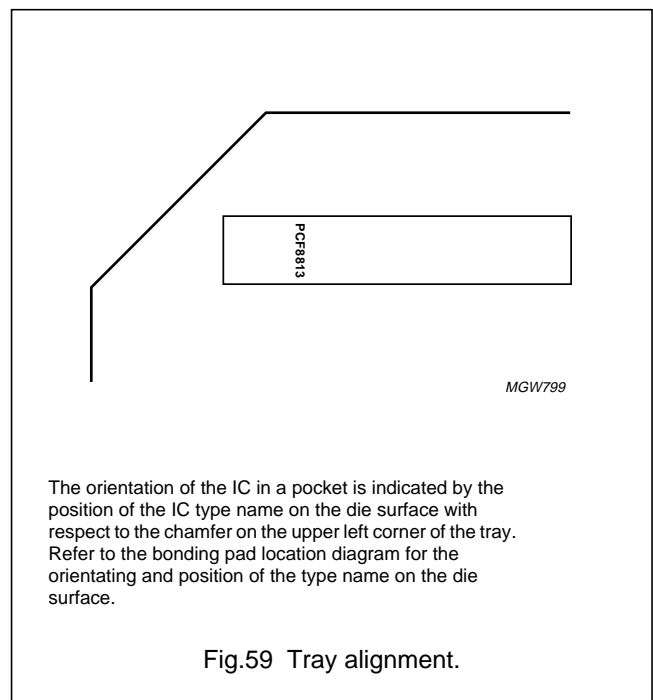

Table 29 Tray dimensions

DIMS	DESCRIPTION	VALUE
A	pocket pitch; x direction	14.66 mm
B	pocket pitch; y direction	3.76 mm
C	pocket width; x direction	10.95 mm
D	pocket width; y direction	1.95 mm
E	tray width; x direction	50.8 mm
F	tray width; y direction	50.8 mm
G	distance from cut corner to pocket (1, 1) centre	10.74 mm
H	distance from cut corner to pocket (1, 1) centre	4.72 mm
J	tray thickness	3.96 mm
K	tray cross section	1.78 mm
L	tray cross section	2.44 mm
M	pocket depth	0.89 mm
x	number of pockets in x direction	3
y	number of pockets in y direction	12



$(67 + 1) \times 102$ pixels matrix LCD driver

PCF8813

22 DATA SHEET STATUS

LEVEL	DATA SHEET STATUS ⁽¹⁾	PRODUCT STATUS ⁽²⁾⁽³⁾	DEFINITION
I	Objective data	Development	This data sheet contains data from the objective specification for product development. Philips Semiconductors reserves the right to change the specification in any manner without notice.
II	Preliminary data	Qualification	This data sheet contains data from the preliminary specification. Supplementary data will be published at a later date. Philips Semiconductors reserves the right to change the specification without notice, in order to improve the design and supply the best possible product.
III	Product data	Production	This data sheet contains data from the product specification. Philips Semiconductors reserves the right to make changes at any time in order to improve the design, manufacturing and supply. Relevant changes will be communicated via a Customer Product/Process Change Notification (CPCN).

Notes

1. Please consult the most recently issued data sheet before initiating or completing a design.
2. The product status of the device(s) described in this data sheet may have changed since this data sheet was published. The latest information is available on the Internet at URL <http://www.semiconductors.philips.com>.
3. For data sheets describing multiple type numbers, the highest-level product status determines the data sheet status.

23 DEFINITIONS

Short-form specification — The data in a short-form specification is extracted from a full data sheet with the same type number and title. For detailed information see the relevant data sheet or data handbook.

Limiting values definition — Limiting values given are in accordance with the Absolute Maximum Rating System (IEC 60134). Stress above one or more of the limiting values may cause permanent damage to the device. These are stress ratings only and operation of the device at these or at any other conditions above those given in the Characteristics sections of the specification is not implied. Exposure to limiting values for extended periods may affect device reliability.

Application information — Applications that are described herein for any of these products are for illustrative purposes only. Philips Semiconductors make no representation or warranty that such applications will be suitable for the specified use without further testing or modification.

24 DISCLAIMERS

Life support applications — These products are not designed for use in life support appliances, devices, or systems where malfunction of these products can reasonably be expected to result in personal injury. Philips Semiconductors customers using or selling these products for use in such applications do so at their own risk and agree to fully indemnify Philips Semiconductors for any damages resulting from such application.

Right to make changes — Philips Semiconductors reserves the right to make changes in the products - including circuits, standard cells, and/or software - described or contained herein in order to improve design and/or performance. When the product is in full production (status 'Production'), relevant changes will be communicated via a Customer Product/Process Change Notification (CPCN). Philips Semiconductors assumes no responsibility or liability for the use of any of these products, conveys no licence or title under any patent, copyright, or mask work right to these products, and makes no representations or warranties that these products are free from patent, copyright, or mask work right infringement, unless otherwise specified.

(67 + 1) × 102 pixels matrix LCD driver**PCF8813**

Bare die — All die are tested and are guaranteed to comply with all data sheet limits up to the point of wafer sawing for a period of ninety (90) days from the date of Philips' delivery. If there are data sheet limits not guaranteed, these will be separately indicated in the data sheet. There are no post packing tests performed on individual die or wafer. Philips Semiconductors has no control of third party procedures in the sawing, handling, packing or assembly of the die. Accordingly, Philips Semiconductors assumes no liability for device functionality or performance of the die or systems after third party sawing, handling, packing or assembly of the die. It is the responsibility of the customer to test and qualify their application in which the die is used.

25 PURCHASE OF PHILIPS I²C COMPONENTS



Purchase of Philips I²C components conveys a license under the Philips' I²C patent to use the components in the I²C system provided the system conforms to the I²C specification defined by Philips. This specification can be ordered using the code 9398 393 40011.

Philips Semiconductors – a worldwide company

Contact information

For additional information please visit <http://www.semiconductors.philips.com>. Fax: +31 40 27 24825

For sales offices addresses send e-mail to: sales.addresses@www.semiconductors.philips.com.

© Koninklijke Philips Electronics N.V. 2004

SCA76

All rights are reserved. Reproduction in whole or in part is prohibited without the prior written consent of the copyright owner.

The information presented in this document does not form part of any quotation or contract, is believed to be accurate and reliable and may be changed without notice. No liability will be accepted by the publisher for any consequence of its use. Publication thereof does not convey nor imply any license under patent- or other industrial or intellectual property rights.

Printed in The Netherlands

R15/02/pp72

Date of release: 2004 Mar 05

Document order number: 9397 750 12934

Let's make things better.

**Philips
Semiconductors**



PHILIPS

This datasheet has been download from:

www.datasheetcatalog.com

Datasheets for electronics components.